

MOVANO RANGE

PANEL VAN, CHASSIS CABS AND PASSENGER CARRIERS
2018 MODELS EDITION 1

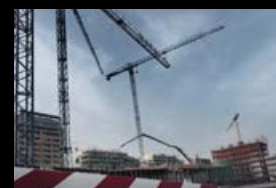

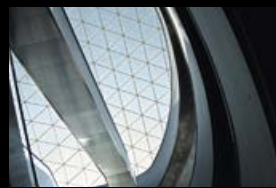

MOVANO. NO JOB TOO BIG.

Big. Strong. And Versatile. That's Movano. With an extensive range of models that give you more of what you need from a commercial vehicle.

Three load lengths. Two roof heights. Large load volumes. High gross vehicle weights and gross combination weights. Plus a choice of front-wheel drive, single rear-wheel drive or twin rear-wheel drive variants. Panel van, chassis cab, crew cab and platform cab variants. Plus a Minibus too and factory-approved conversions.

Add to this an enhanced safety specification plus a range of efficient 2.3CDTi engines including a powerful 170PS (Euro 6) BiTurbo.

Include a driver-friendly cabin environment with plenty of useful storage, plus a host of innovative features that can really make a difference when you're out on the road.

In short, there's 'No Job Too Big' for Movano.

CONTENTS

MOVANO

The Movano range	4
Drivetrains	10
Practicality	12
Cabin interior	14
Engines and transmissions	16
Movano line-up	18
Panel van features	20
Doublecab features	22
17-Seat Minibus features	24
Chassis cab, crew cab and platform cab features	26
Opel conversions	28
Comfort	36
Versatility	38
Options	40
Accessories	44
Colours and trims	46
Specifications	48

Some of the vehicles shown in this brochure include options and accessories available at extra cost. And not all of the features described are available on every model. Please see the Movano Price and Specification Guide, available to download from opel.ie for further details.

MOVANO PANEL VAN AND DOUBLECAB.

With panel vans and doublecabs available in a range of load lengths, heights and drivetrains. Choice is never going to be an issue.



Three vehicle lengths and two heights



GVWs from 3500 to 4500kg



FWD or RWD drivetrains available





MOVANO CHASSIS, CREW AND PLATFORM CABS.

The success of any vehicle conversion stems from the thought put in at the planning stage. All Movano chassis cabs and platform have been engineered to provide a solid base for a host of conversions, with particular emphasis paid to the needs of specialist convertors.



Up to three vehicle lengths with FWD or RWD option



Heavy twin rear wheel option for better traction and higher GVW's



3500kg platform cabs with lower kerbweights for maximum payload capacity









MOVANO PASSENGER CARRIERS.

The Movano 17-seat Minibus combines easy access with optimum levels of safety and comfort – guaranteed to go the distance – whoever you're carrying.



Purpose-built passenger carrier



Designed for maximum safety and comfort



Powerful and efficient turbo-diesel engines



OPEL

Movano

MOVANO



MULTI-DRIVETRAIN CAPABILITIES. SORTED.

Heavy van operators face a variety of challenges. That's why Movano offers a variety of GVW's and no less than three different drivetrains. Whatever your requirement, Movano has it sorted.



Front-wheel drive with a lower loading height and low kerbweight



Single rear-wheel drive for improved towing capability



Twin rear-wheel drive for improved traction and higher GVWs

ACCESS ALL AREAS.

Movano offers superb accessibility – whatever the loading conditions. Rear doors can be swung clear to 180° and locked in place at 90° – providing safe and convenient loading, even where space is restricted.

The wide opening, standard 1270mm sliding side-access door means a Euro pallet can be loaded sideways. While a flat load floor ensures easy access for forklifts. And with payloads from 990-2110kg Movano doesn't only look the business – it actually does the business.



Designed to perform in every situation



Versatile loadspace capabilities and euro-pallet friendly



Impressive payloads of up to 2110kg





CABIN INTERIOR.

Whatever the nature of your business, the Movano cabin creates both a comfortable and versatile workspace that is completely in tune with your individual and professional needs. A well-equipped driving environment with ample storage features, Movano has it covered. And with digital radio and Bluetooth® connectivity as standard and a choice of two optional IntelliLink infotainment systems with fully integrated satellite navigation you'll also be kept well informed and entertained while on-the-road.



Enhanced cab design for total comfort and control



Great place to spend the working day



All you need to stay in touch and entertained





ENGINES AND TRANSMISSIONS.

The Movano range features no less than six variants of the powerful, yet efficient, 2.3CDTi turbo diesel – 110PS and 130PS plus the following BiTurbo units: 130PS, 145PS, 163PS and 170PS. What's more, all engines now meet either V1 or Euro 6 standards through the use of AdBlue technology*. Better still, the high power and torque levels of our BiTurbo models make driving the Movano a pleasure – whatever the load on board.

Powerful turbo-diesel engines

- 2.3CDTi turbo diesel units with up to 110PS and 130PS
- BiTurbo units with 130PS, 145PS, 163PS and 170PS power rating
- Six-speed manual gearbox with electronic shift indicator
- Power-assisted steering
- Tecshift semi-automatic transmission available

Efficiency comes as standard

- AdBlue technology for Euro 6 compatibility
- CO₂ emissions as low as 179g/km
- Start/Stop technology and ECO mode function improves fuel economy
- Outstanding durability with servicing intervals up to 40,000 kilometres/one year (32,000 kilometres on Minibus models)

Options include:

- Automatic locking rear differential
- Engine-driven power take-off
- Gearbox-driven power take-off
- Cruise control

*For more information on AdBlue please visit opel.ie



ENGINES

	Maximum power PS (kW) @ rpm	Maximum torque Nm (lb.ft.) @ rpm	Fuel economy mpg (litres/100km) ^a			CO ₂ emissions (g/km) ^a
			Urban driving	Extra-urban driving	Combined figure	
Panel Vans and Doublecabs						
2.3CDTi (110PS)	110PS (81kW) @ 3500rpm	290Nm (214 lb.ft.) @ 1500rpm	9.0 – 8.9	7.2 – 7.1	7.9 – 7.8	207 – 204
2.3CDTi (110PS) S/S	110PS (81kW) @ 3500rpm	290Nm (214 lb.ft.) @ 1500rpm	8.2 – 8.1	7.2 – 7.1	7.6 – 7.5	197 – 194
2.3CDTi (130PS)	130PS (96kW) @ 3500rpm	320Nm (236 lb.ft.) @ 1500rpm	9.0 – 8.9	7.2 – 7.1	7.9 – 7.8	207 – 204
2.3CDTi BiTurbo (130PS)	130PS (96kW) @ 3500rpm	330Nm (243 lb.ft.) @ 1500rpm	9.6 – 9.3	9.2 – 8.7	9.3 – 9.0	242 – 232
2.3CDTi BiTurbo (145PS) S/S	145PS (107kW) @ 3500rpm	360Nm (266 lb.ft.) @ 1500rpm	8.5 – 7.6	8.6 – 6.7	8.6 – 7.0	222 – 183
2.3CDTi BiTurbo (163PS) S/S	163PS (120kW) @ 3500rpm	360Nm (266 lb.ft.) @ 1500 – 2750rpm	8.2	8.1	8.2	212
2.3CDTi BiTurbo (170PS) S/S	170PS (125kW) @ 3500rpm	380Nm (280 lb.ft.) @ 1500rpm	7.7	7.0	7.3	189
2.3CDTi BiTurbo (170PS) S/S tecshift	170PS (125kW) @ 3500rpm	380Nm (280 lb.ft.) @ 1500rpm	7.7 – 7.9	6.9 – 7.0	7.2 – 7.3	187 – 189
Cabs and Conversions						
2.3CDTi (110PS)	110PS (81kW) @ 3500rpm	290Nm (214 lb.ft.) @ 1500rpm	9.3 – 9.0	7.5 – 7.2	8.2 – 7.9	212 – 207
2.3CDTi (130PS)	130PS (96kW) @ 3500rpm	320Nm (236 lb.ft.) @ 1500rpm	9.3 – 8.9	7.5 – 7.1	8.2 – 7.8	210 – 207
2.3CDTi BiTurbo (130PS)	130PS (96kW) @ 3500rpm	330Nm (243 lb.ft.) @ 1500rpm	9.6 – 9.3	9.2 – 8.7	9.3 – 9.0	242 – 232
2.3CDTi BiTurbo (145PS) S/S	145PS (107kW) @ 3500rpm	360Nm (266 lb.ft.) @ 1500rpm	8.5 – 7.8	8.6 – 6.7	8.6 – 7.0	222 – 183
2.3CDTi BiTurbo (163PS) S/S	163PS (120kW) @ 3500rpm	360Nm (266 lb.ft.) @ 1500 – 2750rpm	8.5 – 8.2	8.6 – 8.1	8.6 – 8.2	222 – 212

^aFuel consumption information is official government environmental data, tested in accordance with the relevant EU directive. Official EU-regulated test data is provided for comparison purposes and actual performance will depend on driving style, road conditions and other non-technical factors. S/S = Start/Stop.

MOVANO LINE-UP.

Whatever business you're in, the Movano presents a complete range of models with a comprehensive line up of drivetrain and configuration options. For example, we offer single rear-wheel drive or twin rear-wheel drive versions. That's on top of our more familiar front-wheel drive models. Depending on the variant you choose there are three load lengths. And two GVWs – 3.5 and 4.5 tonnes.

To help you choose the Movano that's just right for your business, we use a customer-friendly naming scheme. For example an L3 H2 R3500 HD model can be easily identified as shown below.

L = Load length

Four lengths are available ranging from L2-L4

Layout

F = Front wheel drive
R = Rear wheel drive

HD = Heavy duty

Designation used when twin rear wheels are fitted

L3

H2

R

3500

HD

H = Height

Two roof heights are available H2-H3

Gross Vehicle Weight

Two GVWs are available 3500 / 4500



Vehicle illustrated features 270° opening unglazed rear doors, offside sliding side-access door and Ambient Blue two-coat metallic paint all optional at extra cost.

MOVANO LINE-UP

Panel Van – FWD models



L2 H2 F3500



L3 H3 F3500

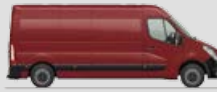

L3 H2 F3500



L3 H3 F3500

RWD models



L3 H2 R3500



L3 H2 R3500 HD/R4500 HD



L4 H2 R3500



L4 H2 R3500 HD/R4500 HD



L3 H3 R3500



L3 H3 R3500 HD/R4500 HD



L4 H3 R3500



L4 H3 R3500 HD/R4500 HD

Doublecab – FWD models



L2 H2 F3500



L3 H2 F3500



L3 H2 R3500

RWD model

Chassis Cab



L2 H1 F3500/R3500
L2 H1 R3500 HD/4500 HD
L3 H1 F3500/R3500
L3 H1 R3500 HD/R4500 HD
L4 H1 R3500 HD/R4500 HD

Crew Cab



L2 H1 F3500/R3500
L3 H1 F3500/R3500
L3 H1 R3500 HD/R4500 HD
L4 H1 R3500 HD/R4500 HD

Platform Cab



L2 H1 F3500
L2 H2 F3500
L3 H1 F3500
L3 H2 F3500

Minibus



L3 H2 F3960: 17-seat model



Vehicle illustrated features 270° opening unglazed rear doors, offside sliding side-access door, full-diameter wheel trims and Poppy Red brilliant paint all optional at extra cost.

PANEL VAN.

Three lengths and two heights. Whatever your transport needs Movano meets them, head-on.

Access and loadspace features include:

- Easy access nearside sliding side-access door
- Full-height steel bulkhead
- Unglazed rear doors
- Floor-mounted, load-securing eyes
- Underfloor spare wheel
- Up to 17.0cu.m (600cu.ft.) max. loadspace volume
- Up to 4383mm (172.6 in.) loadspace length
- Up to 2110kg payload capacity

Loadspace dimensions	mm	inches
Maximum load lengths (L2 - L4)	3083 - 4383	121.4 - 172.6
Maximum load area width	1765	69.5
Width between wheel arches	1380	54.3
Width between wheel arches HD Models	1080	42.5
Maximum heights (H2 - H3)	1798 - 2144	70.8 - 84.4
Rear and side load door(s)	mm	inches
Side-access door(s) width	1270	50.0
Side-access door(s) heights	1684 - 1780	66.3 - 70.1
Rear door aperture width	1577	62.1
Rear door aperture heights	1724 - 1820	67.9 - 71.7
Loadspace volumes	cu.m	cu.ft.
VDA method	10.8 - 14.1	381 - 498
Maximum	9.4 - 17.0	322 - 600
Weights	GVWs kg	Payloads kg
Panel Vans	3500 - 4500	990 - 2110

Not all features and options are available on every model.



Versatile rear doors. Movano rear doors can be swung clear to 180° and locked in place at 90° – providing safe and convenient loading, even where space is restricted. Movano can also be specified with 270° opening rear doors with or without windows.

Vehicle illustrated features resin-coated plywood floor, bulkhead window, glazed rear doors and Poppy Red brilliant paint all optional at extra cost.



Room for all the crew. The Doublecab features four individually contoured rear seats with lap and diagonal seatbelts. Rear storage includes a full-length tray under the seat cushion, plus optional overhead and side net pockets (illustrated above).

DOUBLECAB.

With capacity for up to seven people, a 3.5 tonne GVW and a maximum payload of up to 1305kg, the Movano Doublecab is designed to take your crew and equipment exactly where they need to be.

Features include:*

- Room for up to six passengers
- Up to 9.0cu.m (318cu.ft.) max. loadspace volume
- Up to 2640mm (103.9 in.) loadspace length
- Up to 1305kg payload capacity

Loadspace dimensions	mm	inches
Maximum load lengths - behind rear seats (L2 - L3)	1990 - 2640	78.3 - 103.9
Maximum load lengths - at load floor (L2 - L3)	2175 - 2825	85.6 - 112.2
Maximum load area width	1765	69.5
Width between wheel arches	1380	54.3
Maximum heights	1798 - 1894	70.8 - 74.6
Rear and side load door(s)	mm	inches
Side-access door(s) width	1270	50.0
Side-access door(s) heights	1780	70.1
Rear door aperture width at floor	1577	62.1
Rear door aperture heights	1820	71.7
Loadspace volumes	cu.m	cu.ft.
Maximum	6.9 - 9.0	244 - 318
Weights	GVWs kg	Payloads kg
Doublecab	3500	957 - 1305

*Not all features and options are available on every model.





Vehicle illustrated features overhead and side net pockets, glazed rear doors, full-diameter wheel trims, front fog lights and Poppy Red brilliant paint all optional at extra cost.



1. 17-seater comfort. Light and spacious, Movano Minibus offers comfortable transport for 17, with inertia-reel lap and diagonal seatbelts for every occupant.

2. Overhead storage. Movano Minibus features overhead storage on both sides of the passenger compartment useful for coats and light luggage.

3. Walkway illumination. Individual lighting to each seat row helps guide passengers when it's dark.

17-SEAT MINIBUS.

The purpose-built Movano Minibus provides generous accommodation for 17 people. The last two rows of seats can also be specified with optional floor-mounted fixing rails, freeing up additional load area space quickly without the need for special tools.

Access and loadspace features include:*

- All seats and mountings tested to M1 standards
- Dual front passenger bench seat
- 14-individual rear passenger seats
- Individual saloon lighting for all rear seats
- Illuminated rear passenger walkway
- Overhead storage and coat racks in rear passenger area
- Retracting side step
- Easy-access wide-opening sliding side door
- Selective door-locking with three-button key
- Electronic Stability Programme-plus
- High beam assist
- Lane departure warning
- Front fog lights
- Multi-function trip computer

*Not all features and options are available on every model.

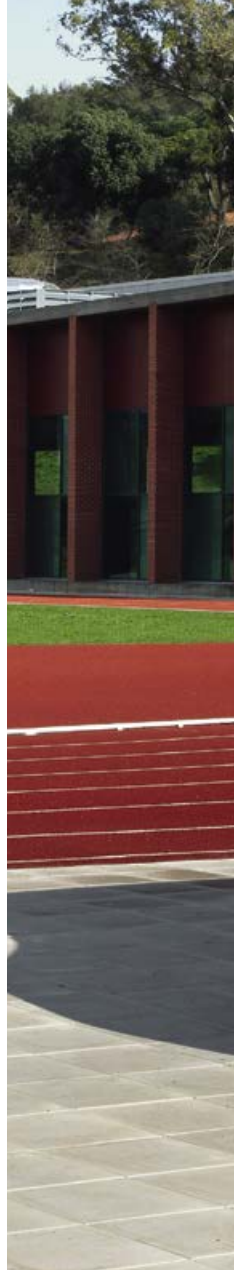



Vehicle illustrated features Halo Silver two-coat metallic paint, optional at extra cost.

MOVANO FLEXIBILITY.

Chassis cab, crew cab and platform cab models provide the perfect base for one of three factory-built conversions – tipper, dropside, box van or our extensive range of approved conversions.

CHASSIS CAB.

Movano chassis cab models feature rugged box section chassis rails, featuring wide top sections with built-in mounting points. The bolted rear under-run bar provides additional in-built safety, as well as ample margins for additional bodywork while retaining outstanding payloads.

- Three load lengths (L2, L3, L4)
- Two GVWs (3500kg or 4500kg)
- Front-wheel drive, rear-wheel drive or heavy-duty twin rear-wheel drive

CREW CAB.

Providing the same choice of body configurations and GVWs as the chassis cab but extra accommodation for four additional crew members.

- Three load lengths (L2, L3, L4)
- Two GVWs (3500kg or 4500kg)
- Front-wheel drive, rear-wheel drive or heavy-duty twin rear-wheel drive

PLATFORM CAB.

Ideal for those conversions requiring a low floor and walk-through access from the cab. The interface panel makes for easy integration of the cab with the conversion body, while an extended-length wiring loom is available to power the rear lights or extended conversions.

- Two load lengths (L2, L3)
- One GVW (3500kg)
- Two roof heights (H1, H2)
- Front-wheel drive



1. Practical and safety-conscious. Whether you're travelling one-up or seven-up, crew cab pays serious attention to the needs of driver and crew. Fabrics are hard-wearing and easy to clean, comfort levels high and safety features impressive; in fact everything you'd expect of this award-winning model.

2. Underseat stowage. Storage is never an issue with our out-of-sight, out-of-mind underseat storage facility.

Log on to opel.ie for more information.



Vehicle illustrated features Halo Silver two-coat metallic paint, optional at extra cost.

OPEL CONVERSIONS.

With chassis cabs, crew cabs, platform cabs and purpose-built factory conversions available, Movano is big on choice. It's incredibly versatile, too, with front-wheel drive, rear-wheel drive and heavy-duty twin rear-wheel drive options available. Of course, all Movano factory conversions carry the full Opel three-year/150,000 kilometres warranty on both the chassis and the conversion.

There's a range of specialist, Opel approved conversions available across our commercial vehicle range too. From Combo through to the Vivaro and Movano ranges, there's an enormous breadth of choice to suit your exact requirements. So, whichever model you choose, you can be confident your Opel Commercial Vehicle will always be 100% fit for purpose.



Models illustrated left to right: L4 H1 R3500 RWD HD box van with optional wind deflector, L4 H1 3500 RWD HD crew cab dropside and L2 H1 R3500 RWD HD tipper.







MOVANO TIPPER.

Particularly suited to the needs of the construction industry, the factory-built Movano tipper features a five-stage chrome-plated underfloor ram and 50° tip angle. The tipping mechanism itself employs a high performance, 2kW electro-hydraulic power pack; the tipping action can be easily operated by one person, using hand-held controls on a wander lead.

Choices available:

- Two load lengths (L2, L3)
- Two GVWs (3500kg or 4500kg)
- Front-wheel drive or heavy-duty, twin rear-wheel drive
- Chassis cab or crew cab models

Standard features include:*

- Tipper platform width 2040mm, length up to 3205mm
- Steel platform and front panel, hot-dip galvanised and dark grey polyester powder coated
- Cab protection including ladder frame
- Remote tipping control with cab-mounted, spiral wander lead
- Side under-run bars
- Top and bottom hinged tailboard
- Double-skinned, anodised aluminium side- and tailboards
- Gantry lugs for ladder restraint
- 'Tipper in action' warning buzzer
- Power pack isolation switch
- Rear light protection grilles (optional)



*Not all features and options are available on every model.



L2 H1 F3500 chassis cab dropside illustrated features full-size wheel trims, optional at extra cost.

MOVANO DROPSIDE.

The Opel-manufactured dropside conversion builds on Movano's in-built flexibility with a host of practical additions. The totally flat load platform – with a load length of up to 4470mm, low loading height and zero wheel arch intrusion – features load restraint lashing eyes and an anti-slip resin finish.

Choices available:

- Three load lengths (L2, L3 and L4)
- Two GVWs (3500kg or 4500kg)
- Front-wheel drive, rear-wheel drive and heavy-duty twin rear-wheel drive
- Chassis cab or crew cab models

Standard features include:*

- Steel load platform with resin-coated wooden floor
- Load platform width 2040mm
- 400mm high, removable, double-skinned, anodised aluminium side- and tailboards
- Recessed, retractable lashing eyes in deck perimeter
- Side under-run bars
- Cab protection including ladder frame
- Removable rear ladder rack and toolbox (optional)



*Not all features and options are available on every model.

MOVANO BOX VAN.

With up to 22cu.m of cargo volume available, the factory-built Movano box van is capable of swallowing a huge load with ease. Inside, the strong yet lightweight body features a completely flat, slip-resistant load floor, accessible via twin 270° opening doors or an aluminium roller shutter (optional at extra cost).

Choices available:

- Two load lengths (L3, L4)
- Two GVWs (3500kg or 4500kg)
- Front-wheel drive, rear-wheel drive or heavy-duty, twin rear-wheel drive

Standard features include:*

- Aluminium frame with smooth-finished polyester walls and doors
- Translucent roof
- Anti-slip floor
- Three carpet-covered aluminium interior protection strips
- Loadspace length up to 4580mm
- Loadspace width 2150mm
- Interior height 2200mm
- Twin 270° opening doors
- Luton head (optional)
- Aluminium rear roller shutter (optional, illustrated right)
- Wind deflector (optional)



*Not all features and options are available on every model.



L4 H1 R3500 HD box van features Luton head, optional at extra cost.

COMFORT.

Movano raises the bar on cabin design, creating a practical, well-equipped driver environment. Outstanding ergonomics – allied to high levels of equipment, maximum ease of access and a superb driving position – come together to create the right travelling and working experience, whatever job you're undertaking.

Movano range features:

- Bluetooth® connectivity and USB for smartphones and MP3 players
- Digital radio
- Steering column-mounted audio and telephone controls
- Aux-in socket
- Availability of two optional fully integrated satellite navigation systems

Movano interior. There's no problem in finding the ideal driving position in a Movano with a height-adjustable steering wheel and a driver's seat that's adjustable for height, reach and rake. You can even specify air conditioning as an extra-cost option that features a chilled glovebox facility. The well-designed cabin also features clear and concise instrumentation and with infotainment that includes both digital radio, Bluetooth® connectivity and an optional sat nav system, it's one workspace that you won't mind spending time in.



Model illustrated features Convenience Pack and bulkhead window optional at extra cost.



1. **Improved instruments.** Clear and easier to read in a simple, no-nonsense binnacle.
2. **Drinks holders.** Two fascia-mounted drinks holders are standard on all models.
3. **Bluetooth® connectivity.** Virtually universal in compatibility and enables hands-free mobile phone communication.
4. **Flat-folding middle seat back.** Flat work surface with two drinks holders and storage tray.

VERSATILITY.

Movano's cabin is equipped with plenty of large – and useful – storage facilities as standard and extensive fascia storage.

But for some operators, we recognise that won't be enough! The Convenience Pack option help transform the cab into a state-of-the-art, full-on mobile office.

Movano range features:

- Twin overhead storage shelves
- 11-litre passenger glovebox
- Large door pockets
- Coin and ticket holders
- Facia-mounted cup holders

Convenience Pack. This versatile optional extra features a retractable fascia document clip, mutli-function bench seat with folding seat back on centre passenger seat including swivelling work tray and underseat storage.

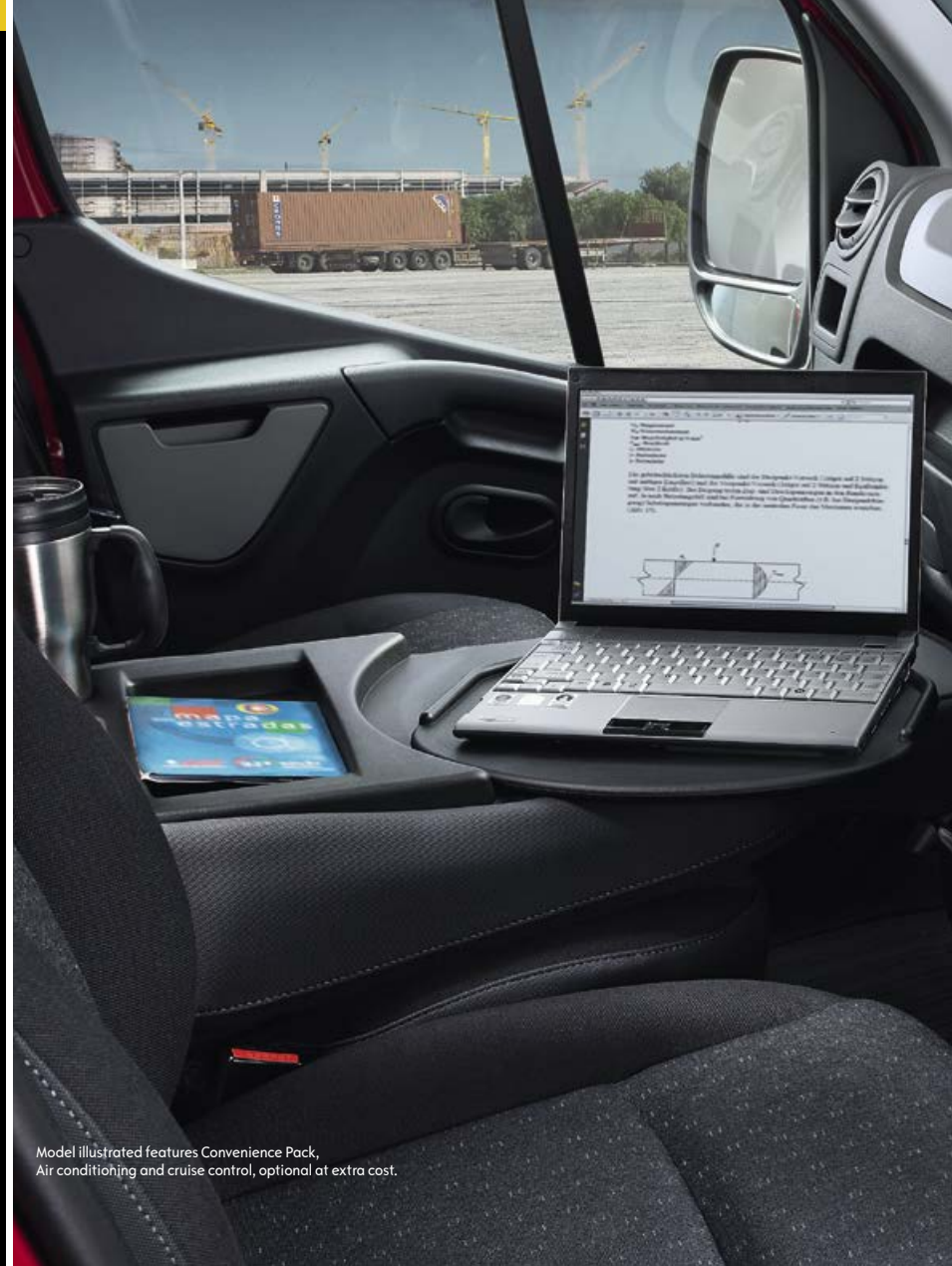

Model illustrated features Convenience Pack, Air conditioning and cruise control, optional at extra cost.



1. Facia storage. All Movano models feature a semi-covered tray on top of the fascia.

2. Overhead storage. There's a handy shelf above both driver and passengers.

3. Large door pockets. A two-litre water bottle or other bulky items can be accommodated.

4. Underseat storage. Convenience Pack also includes a large enclosed storage space accessed via the folding seat cushions.

MOVANO OPTIONS*

Loadspace

Movano panel vans' excellent loadspace credentials – allied to maximum accessibility – are assisted by a wider choice of cargo area options than ever before. These options allow you to create the loadspace that's just right for your business. Here's just a selection of the options available.



1. Load area protective panels. Half-height load trim panels help safeguard the side walls from everyday wear and tear. Standard on RWD models.

2. Protective floor. A resin-coated plywood floor protects the load floor from damage.

3. Full-height load area panelling and wheel arch protection. Plywood panels provide maximum loadspace protection.

*Optional at extra cost.

Interior

Creating an optimal working environment couldn't be easier with Movano. With a variety of seating options, a host of additional comfort features and a great infotainment system including satellite navigation, Movano has it all to offer – whatever job you're undertaking. Here are just some of the highlights. Please refer to the latest Movano Price and Specification Guide available to download at www.opel.ie for availability by model.



4. Air-suspended driver's seat. The eight-way adjustable, air-suspended driver's seat features an armrest and adjustable suspension sensitivity for maximum comfort in all conditions.

'Comfort' seats. Driver's seat features height-adjustment, adjustable lumbar support and armrest. A single 'Comfort' front passenger seat is also available (not illustrated).

5. Air conditioning and electronic climate control (ECC). The air-con option comes complete with pollen filter and a chilled glovebox. Aids demisting and provides a fresher travelling environment all year round. Move up to ECC (illustrated) and as well as an air conditioned cab you'll also be able to more precisely control your environment through thermostatically-controlled temperature adjustment.

6. NAVI 50 IntelliLink. Digital radio/stereo radio/aux-in socket/Bluetooth® hands-free phone connectivity and audio streaming/USB facility with a 7-inch colour touchscreen, two 20-watt speakers and dynamic satellite navigation system with western European map coverage.

NAVI 80 IntelliLink. The intuitive, top-of-the-range system with 3-D viewing, integrated voice control, USB video player/photo reader and TomTom LIVE services till 2020 without charge for real-time traffic information. The separate overhead 7-inch display also shows the view for the optional rear view camera (not illustrated).

The air conditioning in vehicles with N1, N2 or M2 type approval relies upon fluorinated greenhouse gases (R134a) for its functioning. The front system contains a quantity of overall 580g of R134a, which corresponds to a CO₂ equivalent of 0.83 tons. The front and rear system in versions with up to 9-seats contains a quantity of overall 1,100g of R134a, which corresponds to a CO₂ equivalent of 1.57 tons. The front and rear system in versions with more than 16-seats contains a quantity of overall 1,700g of R134a, which corresponds to a CO₂ equivalent of 2.43 tons. The global warming potential amounts to 1430. Information acc. to R (EU) No. 517/2014.

Exterior

Enhanced security. Higher safety levels. A little more protection. Or just the added practicality of a tow bar. Whatever your individual need, Movano options have it covered. We also offer a range of mechanical options that can seriously add to Movano's performance as a working vehicle.



Engine-driven power take-off. Movano models can be specified with an engine-driven PTO. This can be used to drive a fridge compressor or other light applications.

Gearbox-driven power take-off. RWD versions of Movano can be supplied with a gearbox-driven PTO. Particularly useful for companies operating heavy-duty ancillary equipment.



Rear parking distance sensors. Optional rear parking distance sensors provide an audible warning to help prevent accidental damage when reversing.

Fixed tow bar. As the name suggests, the unit and ball are permanently fixed – and, once fitted, cannot be readily removed. 13-pin electrics are also included.

Automatic locking rear differential (ALRD). To assist driving in rough or slippery conditions ALRD is optional at extra cost on RWD models.

Alarm system. The optional anti-theft alarm protects the engine compartment and uses sensors to guard both the cab and load area.



Front fog lights. Improved forward vision and reduced glare in foggy weather conditions.

Airbag options. A driver's airbag is standard across the range. An optional front passengers' airbag with deactivation switch is also available.

Pneumatic suspension. For easier loading and unloading, and improved ride comfort.

Increased engine speed. Movano is available with an increased engine idle speed option. This enables power to be supplied to ancillary equipment without affecting the battery charge. An essential option for vehicle converters.

MOVANO OPTION PACKS.

Movano option packs provide a 'bundle' of features at a highly attractive price, allowing you to tailor your equipment package to suit the individual demands of your business.



Convenience Pack

- Retractable document clip in fascia
- 'Comfort' driver's seat
- Bulkhead soundproofing
- Multi-function office bench seat with folding seat back on centre passenger seat including swivelling work tray
- Storage under bench seat accessed by folding seat cushions
- 'One-touch down' facility for driver's electrically operated window

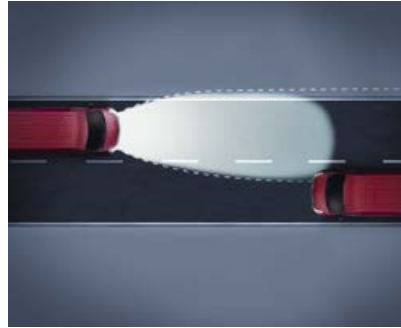

Advanced Safety Assist Pack*

- Lane departure warning
- High beam assist
- Multi-function trip computer
- Front fog lights



Construction Pack (RWD models)

- Tow bar with 13-pin electrics
- Automatic locking rear differential
- Air-suspended driver's seat



Lighting Pack

- Automatic lighting control
- Rain-sensitive windscreen wipers
- Front fog lights
- Static cornering lights
- Door-to-door illumination

*Standard on Minibus and 4500 models.

MOVANO ACCESSORIES.

Genuine Opel Accessories are the right choice for your Movano. The list below is just a small sample of the range available.

Other accessories include:

Safety

- Safety pack
- MetaSystem rear parking distance sensors
- First aid kit and warning triangle
- Hi-visibility vest

Practical

- MetaSystem alarm
- Spare bulb kit
- Fuel can
- Stretch tow rope
- Jump leads
- Fire extinguisher (1kg or 2kg)
- Fire extinguisher bracket (1kg or 2kg)
- Tyre inflation kit

Security

- Steering wheel security bar

Protection

- Seat covers
- Audio accessories

Audio accessories

- Portable CD storage bag or box
- Sunvisor CD storage

Towing

- Flange tow bar
- Towing electrics (7-pin or 13-pin)
- Towing electrical adaptors (7/13-pin or 13/7-pin or 12S adaptor)



Models illustrated feature Glazing Pack, optional at extra cost.



1. Roof base carrier. City crash test approved, the transverse-fitting aluminium roof bars provide a solid platform for a range of roof carriers. They feature an oval-shaped profile and attach directly to mounting points on the roof itself using a secure, T-track connector. Up to six bars can be fitted per vehicle and the maximum load per bar is 50kg. Maximum load per roof is 200kg (including the weight of all fitted bars).

2. Steel ladder. Steel-constructed but with a smart, aluminium-look finish, the rear ladder is firmly affixed to the rear door of the vehicle.



3. Roof rack tray. With dimensions tailored to the individual vehicle, the aluminium roof rack tray offers a maximum load capacity of 200kg.

4. Walkway for roof rack tray. Made from lightweight but sturdy perforated aluminium and for use with the roof rack tray, the walkway enhances access to the roof.

5. Trailer hook. Particularly suited to heavier loads, the trailer hook is finished in an anti-corrosive epoxy powder treatment.

6. Rear window protection grilles. Constructed from 1mm thick epoxy coated steel, the rear window protection grilles help avoid theft while retaining rearward visibility.

7. Mudflaps. Movano's smart, grey, moulded mudflaps are specifically designed to protect the lower bodywork from stone chips, grit and other road material.

8. Carpet mats. Constructed from smart yet hard-wearing textile – and available in dark grey – the one-piece Movano-branded carpet mat features fittings to prevent slippage in use.

MOVANO COLOURS* AND TRIMS.

Movano's business-like appearance is exemplified by the smart choice of colours available. The cloth or vinyl trims have been chosen as much for their hard-wearing properties as they have for their visual appeal.

Arctic White – solid



Signal Blue – solid



Mandarin Orange – solid



North Sea Blue – solid



Saffron Yellow – solid



Ink Blue – solid



Poppy Red – brilliant



Ambient Blue – two-coat metallic



Halo Silver – two-coat metallic



Pearl Black – two-coat metallic



Due to the limitations of the printing process, the colours reproduced may vary from the actual colour. As a result they should be used as a guide only.

Please note: Certain alternative colours are available for special order on Movano. Restrictions apply so please consult your Commercial Vehicle dealers for more details. Only the cab is painted on factory conversion models. The Dropside and Tipper models feature an aluminium finish and the Box Body is finished in white.

* Please refer to the latest Movano Price and Specification Guide available from www.opel.ie for details of colour availability by model and prices.



Grey Pulse cloth

Hard-wearing Grey Pulse cloth trim is fitted as standard across the range.



Grey vinyl*

Alternatively, grey vinyl trim can be specified at extra cost for customers requiring a more workmanlike, wipe-clean option.

EXTERIOR COLOURS

Trim	Grey Pulse cloth	Grey vinyl*
Solid		
Arctic White	•	•
Signal Blue	•	•
Mandarin Orange	•	•
North Sea Blue	•	•
Saffron Yellow	•	•
Ink Blue	•	•
Brilliant		
Poppy Red	•	•
Two-coat metallic		
Halo Silver	•	•
Ambient Blue	•	•
Pearl Black	•	•

• = Available

*Grey vinyl seat trim is optional at extra cost.

MOVANO FWD PANEL VAN

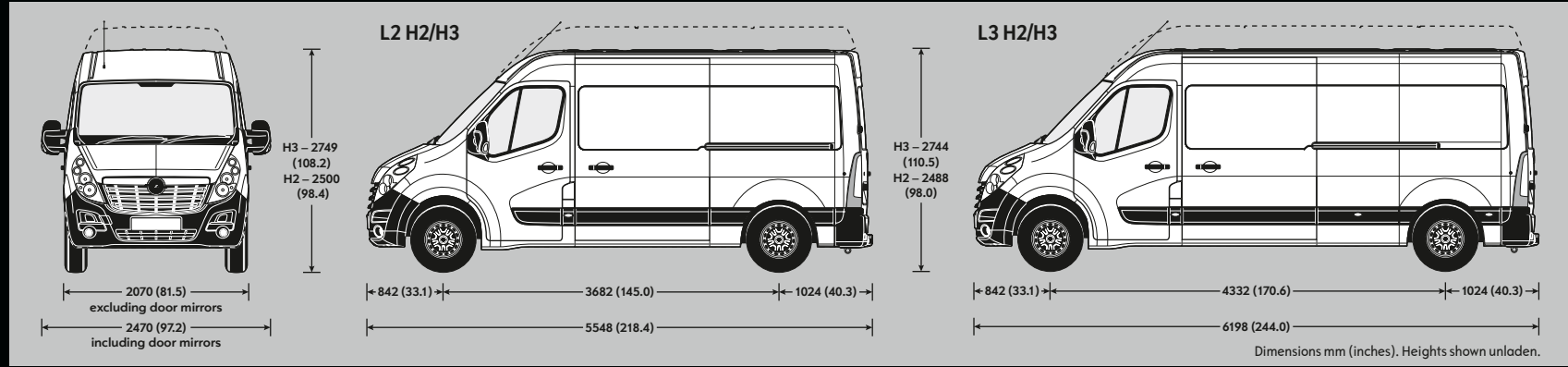

LOADSPACE DIMENSIONS MM (INCHES) – FWD PANEL VAN

	L2	L3
Maximum length	3083 (121.4)	3733 (147.0)
Maximum width	1765 (69.5)	1765 (69.5)
Width between wheel arches	1380 (54.3)	1380 (54.3)
Maximum height – H2	1894 (74.6)	1894 (74.6)
Maximum height – H3	2144 (84.4)	2144 (84.4)

LOADSPACE ACCESS MM (INCHES) – FWD PANEL VAN

	L2	L3
Side door aperture height	1780 (70.1)	1780 (70.1)
Side door aperture width	1270 (50.0)	1270 (50.0)
Rear door aperture height	1820 (71.7)	1820 (71.7)
Rear door aperture width	1577 (62.1)	1577 (62.1)
Loading height	562 (22.1)	557 (21.9)

LOADSPACE VOLUMES CU.M (CU.FT.) – FWD PANEL VAN

	L2 H2	L2 H3	L3 H2	L3 H3
Panel Van – Maximum	10.8 (381)	12.3 (434)	13.0 (459)	14.8 (523)
– VDA	9.4 (322)	–	11.3 (399)	–

WEIGHTS KG – FWD PANEL VAN

GVW		L2 H2	L2 H3	L3 H2	L3 H3
3500 FWD**	Minimum Mass*	2009	2050	2090	2130
	Payload*	1476	1435	1395	1355

* = For definitions please refer to Glossary of Terms.

** = BiTurbo models add 9kg-10kg to the vehicle weight with a corresponding reduction in payload.

FUEL ECONOMY AND EMISSIONS – FWD PANEL VAN

	Fuel economy litres/100km [#]			CO ₂ emissions (g/km) [#]
	Urban driving	Extra-urban driving	Combined figure	
L2 H2/H3 FWD				
2.3CDTi (110PS/130PS)	8.9	7.1	7.8	204
2.3CDTi (110PS) S/S ecoFLEX	8.1	7.1	7.5	194
2.3CDTi BiTurbo (145PS) S/S	7.6	6.7	7.0	183
2.3CDTi BiTurbo (170PS) S/S Tecshift	7.8	6.9	7.2	187
L3 H2/H3 FWD				
2.3CDTi (110PS/130PS)	9.0	7.2	7.9	207
2.3CDTi (110PS) S/S ecoFLEX	8.2	7.2	7.6	197
2.3CDTi BiTurbo (145PS) S/S	7.8	6.8	7.2	186
2.3CDTi BiTurbo (170PS) S/S Tecshift	7.9	7.0	7.3	189

[#]Fuel consumption information is official government environmental data, tested in accordance with the relevant EU directive. Official EU-regulated test data is provided for comparison purposes and actual performance will depend on driving style, road conditions and other non-technical factors.

S/S = Start/Stop.

PLATED WEIGHTS AND TOWING DATA KG – PANEL VAN / DOUBLECAB

	Plated weights		Towing weights		Plated Gross Combination Weights (GCW)
	Front axle	Rear axle	Braked	Unbraked	
FWD 3500	1850	2100	2500	750	6000
RWD 3500	1850	2300	2500	750	6000
RWD 3500 HD	1850	2800	3000	750	6500
RWD 4500 HD	1850	3200	3000	750	7500

PLATED WEIGHTS AND TOWING DATA KG – CAB / CONVERSION

	Plated weights		Towing weights		Plated Gross Combination Weights (GCW)
	Front axle	Rear axle	Braked	Unbraked	
FWD 3500	1850	2100	2500	750	6000
RWD 3500	1850	2300	2500	750	6000
RWD 3500 HD	1850	2800	3500	750	7000
RWD 4500 HD	1850	3200	3000	750	7500

Gross plated weights (including axle weights) quoted on the vehicle plate must never be exceeded.

MOVANO RWD PANEL VAN

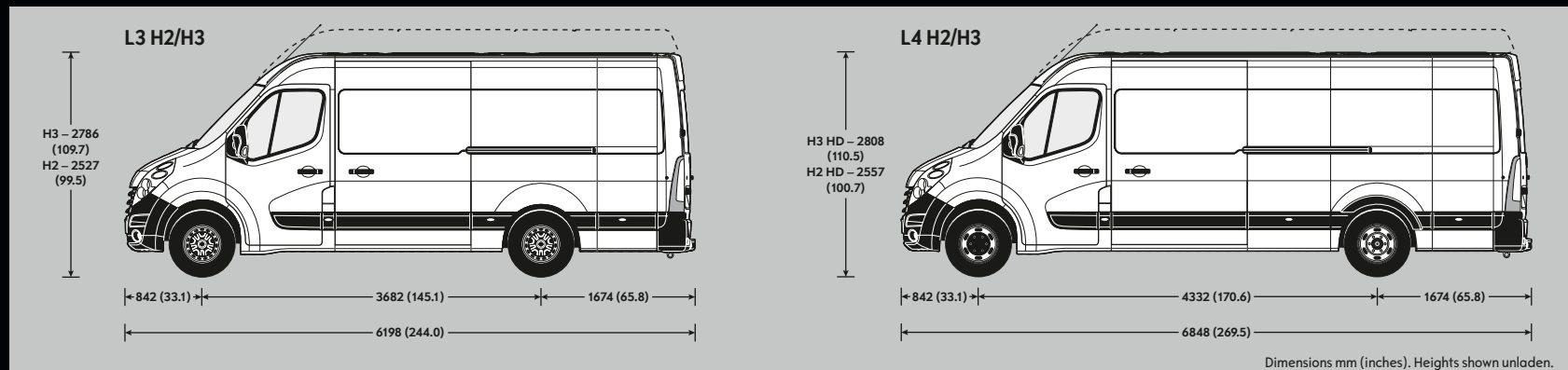

Dimensions mm (inches). Heights shown unladen.

LOADSPACE DIMENSIONS MM (INCHES) – RWD PANEL VAN

	L3	L4
Maximum length	3733 (147.0)	4383 (172.6)
Maximum width	1765 (69.5)	1765 (69.5)
Width between wheel arches	1380 (54.3)	1380 (54.3)
Maximum height – H2	1798 (70.8)	1798 (70.8)
Maximum height – H3	2048 (80.6)	2048 (80.6)

LOADSPACE ACCESS MM (INCHES) – RWD PANEL VAN

	L3	L4
Side door aperture height	1684 (66.3)	1684 (66.3)
Side door aperture width	1270 (50.0)	1270 (50.0)
Rear door aperture height	1724 (67.9)	1724 (67.9)
Rear door aperture width	1577 (62.1)	1577 (62.1)
Loading heights	696 (27.4) – 724 (28.5)	717 (28.2)

LOADSPACE VOLUMES CU.M (CU.FT.) – RWD PANEL VAN

	L3 H2	L3 H3	L4 H2	L4 H3
Panel Van – Maximum	12.4 (438)	14.2 (501)	14.9 (526)	17.0 (600)
– VDA	10.9 (385)	12.2 (431)	12.9 (456)	14.1 (498)

WEIGHTS KG – RWD PANEL VAN

GVW		L3 H2	L3 H3	L4 H2	L4 H3
3500 RWD	Minimum Mass*	2356	2356	2398	2429
	Payload*	1129	1129	1087	1056

* = For definitions please refer to Glossary of Terms.

FUEL ECONOMY AND EMISSIONS – RWD PANEL VAN

	Fuel economy litres/100km [#]			CO ₂ emissions (g/km) [#]
	Urban driving	Extra-urban driving	Combined figure	
L3 H2/H3 RWD				
3500 2.3CDTi BiTurbo (130PS)	9.3	8.7	9.0	232
3500 2.3CDTi BiTurbo (145PS) S/S	8.2	8.1	8.2	212
L4 H2/H3 RWD				
3500 2.3CDTi BiTurbo (130PS)	9.3	8.7	9.0	232
3500 2.3CDTi BiTurbo (145PS/163PS) S/S	8.2	8.1	8.2	212

#Fuel consumption information is official government environmental data, tested in accordance with the relevant EU directive. Official EU-regulated test data is provided for comparison purposes and actual performance will depend on driving style, road conditions and other non-technical factors.

S/S = Start/Stop.

MOVANO RWD HD PANEL VAN

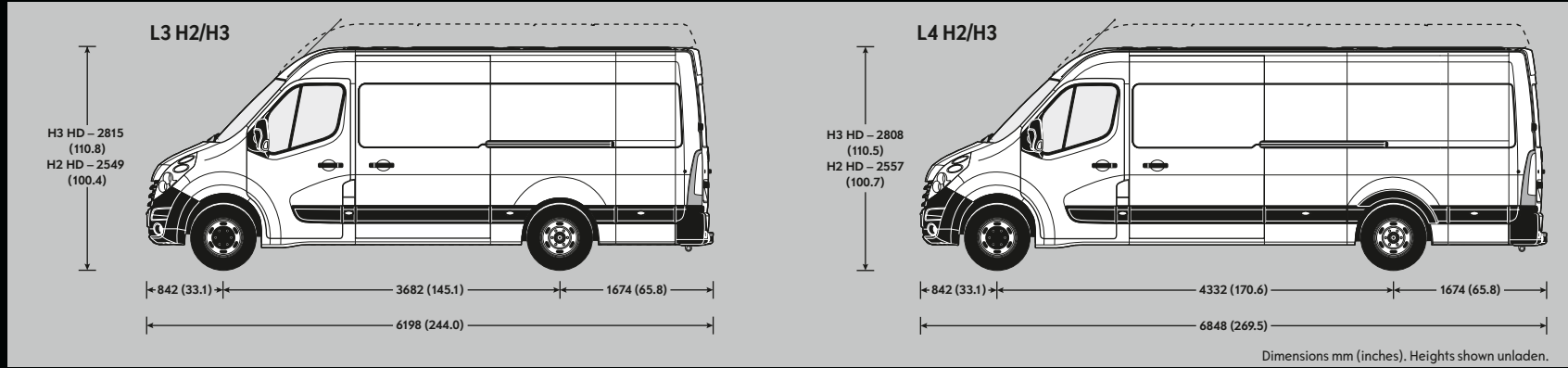

Dimensions mm (inches). Heights shown unladen.

LOADSPACE DIMENSIONS MM (INCHES) – RWD HD PANEL VAN

	L3	L4
Maximum length	3733 (147.0)	4383 (172.6)
Maximum width	1765 (69.5)	1765 (69.5)
Width between wheel arches	1080 (42.5)	1080 (42.5)
Maximum height – H2	1798 (70.8)	1798 (70.8)
Maximum height – H3	2048 (80.6)	2048 (80.6)

LOADSPACE ACCESS MM (INCHES) – RWD HD PANEL VAN

	L3	L4
Side door aperture height	1684 (66.3)	1684 (66.3)
Side door aperture width	1270 (50.0)	1270 (50.0)
Rear door aperture height	1724 (67.9)	1724 (67.9)
Rear door aperture width	1577 (62.1)	1577 (62.1)
Loading heights	723 (28.4) – 724 (28.5)	717 (28.2)

LOADSPACE VOLUMES CU.M (CU.FT.) – RWD HD PANEL VAN

	L3 H2	L3 H3	L4 H2	L4 H3
Panel Van – Maximum	12.4 (438)	14.2 (501)	14.9 (526)	17.0 (600)
– VDA	10.7 (378)	12.0 (424)	12.7 (448)	13.9 (491)

WEIGHTS KG – RWD HD PANEL VAN

GVW		L3 H2	L3 H3	L4 H2	L4 H3
3500 RWD HD	Minimum Mass*	2375	2408	2453	2495
	Payload*	1110	1077	1032	990
4500 RWD HD	Minimum Mass*	2375	2408	2453	2495
	Payload*	2110	2077	2032	1990

* = For definitions please refer to Glossary of Terms.

FUEL ECONOMY AND EMISSIONS – RWD HD PANEL VAN

	Fuel economy litres/100km [#]			CO ₂ emissions (g/km) [#]
	Urban driving	Extra-urban driving	Combined figure	
L3 H2/H3 RWD HD				
3500 HD 2.3CDTi BiTurbo (130PS)	9.6	9.2	9.3	242
3500 HD 2.3CDTi BiTurbo (145PS) S/S	8.5	8.6	8.6	222
L4 H2/H3 RWD HD				
3500 HD 2.3CDTi BiTurbo (130PS)	9.6	9.2	9.3	242
3500 HD 2.3CDTi BiTurbo (145PS) S/S	8.5	8.6	8.6	222

#Fuel consumption information is official government environmental data, tested in accordance with the relevant EU directive. Official EU-regulated test data is provided for comparison purposes and actual performance will depend on driving style, road conditions and other non-technical factors.

S/S = Start/Stop.

MOVANO FWD DOUBLECAB

L2 H2

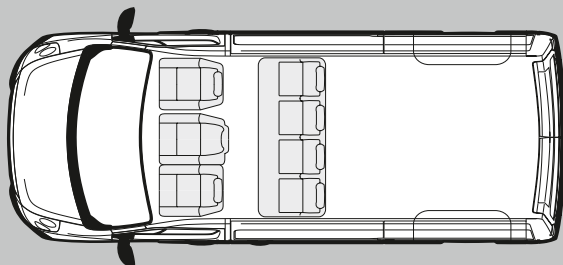

L3 H2

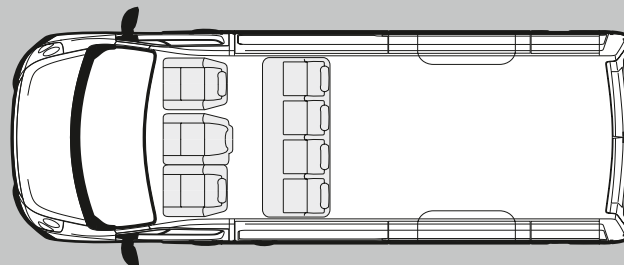

For exterior dimensions see FWD Panel Van.

LOADSPACE DIMENSIONS MM (INCHES) – FWD DOUBLECAB

	L2	L3
Maximum length at load area	2175 (85.6)	2825 (111.2)
Maximum length behind rear seats	1990 (78.3)	2640 (103.9)
Maximum width	1765 (69.5)	1765 (69.5)
Width between wheel arches	1380 (54.3)	1380 (54.3)
Maximum height	1894 (74.6)	1894 (74.6)

LOADSPACE ACCESS MM (INCHES) – FWD DOUBLECAB

	L2	L3
Side door aperture height	1780 (70.1)	1780 (70.1)
Side door aperture width	1270 (50.0)	1270 (50.0)
Rear door aperture height	1820 (71.7)	1820 (71.7)
Rear door aperture width	1577 (62.1)	1577 (62.1)
Loading height	562 (22.1)	557 (21.9)

LOADSPACE VOLUMES CU.M (CU.FT.) – FWD DOUBLECAB

	L2 H2	L3 H2
Doublecab	6.9 (244)	9.0 (318)

WEIGHTS KG – FWD DOUBLECAB

GVW		L2 H2	L3 H2
3500 FWD**	Minimum Mass*	2205	2286
	Payload*	1305	1224

* = For definitions please refer to Glossary of Terms.

** = BiTurbo models add 9kg-10kg to the vehicle weight with a corresponding reduction in payload.

FUEL ECONOMY AND EMISSIONS – FWD DOUBLECAB

	Fuel economy litres/100km [#]			CO ₂ emissions (g/km) [#]
	Urban driving	Extra-urban driving	Combined figure	
L2 H2 FWD				
3500 2.3CDTi (130PS)	9.0	7.2	7.9	207
3500 2.3CDTi BiTurbo (145PS) S/S	7.8	6.8	7.2	186
3500 2.3 CDTi BiTurbo (170PS) S/S Tecshift	7.7	7.0	7.3	189
L3 H2 FWD				
3500 2.3CDTi (130PS)	9.0	7.2	7.9	207
3500 2.3CDTi BiTurbo (145PS) S/S	7.8	6.8	7.2	186
3500 2.3 CDTi BiTurbo (170PS) S/S Tecshift	7.7	7.0	7.3	189

#Fuel consumption information is official government environmental data, tested in accordance with the relevant EU directive. Official EU-regulated test data is provided for comparison purposes and actual performance will depend on driving style, road conditions and other non-technical factors.

S/S = Start/Stop.

MOVANO RWD DOUBLECAB

L3 H2

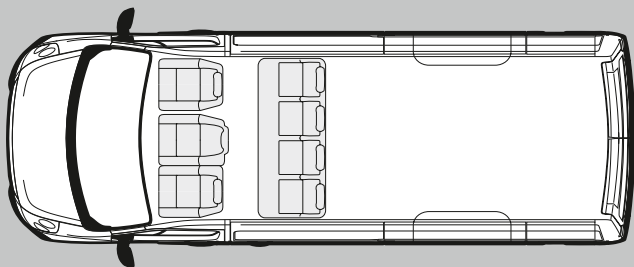

For exterior dimensions see RWD Panel Van.

LOADSPACE DIMENSIONS MM (INCHES) – RWD DOUBLECAB

	L3
Maximum length at load area	2825 (111.2)
Maximum length behind rear seats	2640 (103.9)
Maximum width	1765 (69.5)
Width between wheel arches	1380 (54.3)
Maximum height	1798 (70.8)

LOADSPACE ACCESS MM (INCHES) – RWD DOUBLECAB

	L3
Side door aperture height	1684 (66.3)
Side door aperture width	1270 (50.0)
Rear door aperture height	1724 (67.9)
Rear door aperture width	1577 (62.1)
Loading heights	674 (26.5) – 696 (27.4)

LOADSPACE VOLUMES CU.M (CU.FT.) – RWD DOUBLECAB

	L3
Doublecab	8.4 (297)

WEIGHTS KG – RWD DOUBLECAB

GVW		L3 H2
3500 RWD	Minimum Mass*	2553
	Payload*	957

* = For definitions please refer to Glossary of Terms.

FUEL ECONOMY AND EMISSIONS – RWD DOUBLECAB

L3 H2 RWD	Fuel economy litres/100km [#]			CO ₂ emissions (g/km) [#]
	Urban driving	Extra-urban driving	Combined figure	
3500 2.3CDTi BiTurbo (130PS)	9.3	8.7	9.0	232
3500 2.3CDTi BiTurbo (145PS) S/S	8.2	8.1	8.2	212

#Fuel consumption information is official government environmental data, tested in accordance with the relevant EU directive. Official EU-regulated test data is provided for comparison purposes and actual performance will depend on driving style, road conditions and other non-technical factors.

S/S = Start/Stop.

MOVANO MINIBUS 17-SEAT

FWD L3 H2

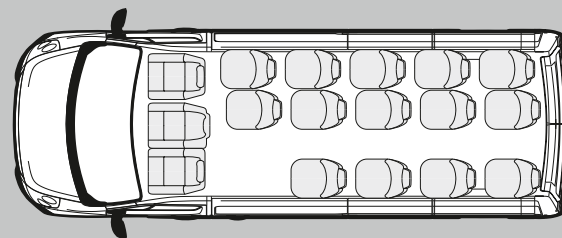
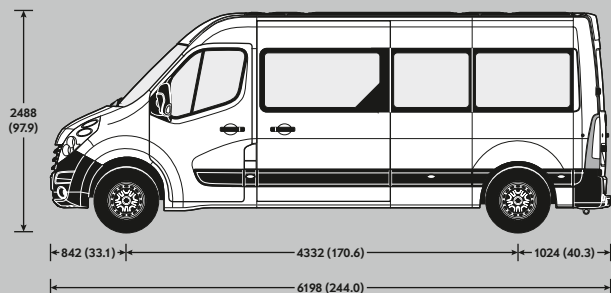

Measurements are shown in millimetres (inches).

LOADSPACE/CABIN ACCESS MM (INCHES) – MINIBUS

Side door aperture height	1780 (70.1)
Side door aperture width	1270 (50.0)
Rear door aperture height	1820 (71.7)
Rear door aperture width	1577 (62.1)

WEIGHTS KG – MINIBUS

GVW		L3 H2
3960 FWD	Minimum Mass*	2660
	Payload*	1340

* = For definitions please refer to Glossary of Terms.

PLATED WEIGHTS AND TOWING DATA KG – MINIBUS

L3 H2 FWD	Plated weights		Towing weights		Plated Gross Combination Weights (GCW)
	Front axle	Rear axle	Braked	Unbraked	
3960	1850	2100	n/a	n/a	n/a

Gross plated weights (including axle weights) quoted on the vehicle plate must never be exceeded.
n/a = Not applicable.

ENGINES / TECHNICAL DATA

	2.3CDTi (110PS) BlueInjection with or without Start/Stop	2.3CDTi (130PS) BlueInjection	2.3CDTi BiTurbo (130PS) BlueInjection
Capacity	2298cc	2298cc	2298cc
Maximum power	110PS (81kW) @ 3500rpm	130PS (96kW) @ 3500rpm	130PS (96kW) @ 3500rpm
Maximum torque	290Nm (214 lb.ft.) @ 1500rpm	320Nm (236 lb.ft.) @ 1500rpm	330Nm (243 lb.ft.) @ 1500rpm
Configuration	4 cylinders, 4 valves per cylinder, double overhead camshafts		
Fuel/induction system	Fixed geometry turbocharger and intercooler. Common rail fuel injection	Twin variable geometry turbochargers and intercoolers. Common rail fuel injection	
Emission compliance	Euro 6		Euro VI
Service interval	40,000km or two years (whichever occurs sooner)		

	2.3CDTi BiTurbo (145PS) BlueInjection with Start/Stop	2.3CDTi BiTurbo (163PS) BlueInjection with Start/Stop	2.3CDTi BiTurbo (170PS) BlueInjection with Start/Stop
Capacity	2298cc	2298cc	2298cc
Maximum power	145PS (107kW) @ 3500rpm	163PS (120kW) @ 3500rpm	170PS (125kW) @ 3500rpm
Maximum torque	360Nm (266 lb.ft.) @ 1500rpm	360Nm (266 lb.ft.) @ 1500-2750rpm	380Nm (280 lb.ft.) @ 1500rpm
Configuration	4 cylinders, 4 valves per cylinder, double overhead camshafts		
Fuel/induction system	Twin variable geometry turbochargers and intercoolers. Common rail fuel injection		
Emission compliance	Euro 6 (FWD) / Euro VI (RWD)	Euro VI	Euro 6
Service interval	40,000km (32,000km on Minibus models) or two years (whichever occurs sooner)		

Vehicles with BlueInjection technology will need regular AdBlue® top-ups also between servicing requirements. An indicator integrated into the on-board computer will warn you when you need to top up. More information under www.Opel.ie In accordance with regulations R (EC) No. 715/2007 and R (EC) No. 692/2008 (in the versions respectively applicable).

Transmissions

Six-speed manual gearbox:

FWD models:

- Transverse engine/gearbox
- L2/L3 models

RWD / RWD HD models:

- Longitudinal engine/gearbox
- L2/L3/L4 models
- Six-speed Tecshift transmission – available at extra cost

Electrical

- 95Ah maintenance-free battery
- 185A alternator

Body

- Six years' body panel anti-perforation warranty
- Galvanised body panels
- Anti stone-chip mastic coating on sills
- Flush-fitted windscreen and rear door glass (when specified)
- Detachable front towing eye
- Rear towing eye

Brakes

Front ventilated disc brakes:

- FWD / RWD / RWD HD 302mm x 28mm

Rear disc brakes:

- FWD / RWD 305mm x 12mm
- RWD HD 305mm x 18mm

Fuel tank capacity

- 80 litres (17.6 gallons)
- 105 litres (23.1 gallons) optional

Steering

- Power-assisted rack and pinion system
- Turns lock-to-lock: 3.7

Turning circles:

	Kerb-to-kerb	Wall-to-wall
FWD / RWD L2	13.6m (44.6ft.)	14.1m (46.2ft.)
FWD L3	15.7m (51.5ft.)	16.2m (53.1ft.)
RWD / RWD HD L3	13.6m (44.6ft.)	14.1m (46.2ft.)
L4	15.7m (51.5ft.)	16.2m (53.1ft.)

Suspension

Front suspension:

- MacPherson type
- Independent double wishbones
- Coil springs
- Telescopic dampers

Rear suspension:

- Tubular axle
- Telescopic dampers
- Variable rate leaf springs

FWD models:

- Single leaf springs
- Single rear wheels

RWD models:

- Double leaf springs
- Single rear wheels

RWD HD models:

- Triple leaf springs
- Twin rear wheels

MOVANO CHASSIS CAB

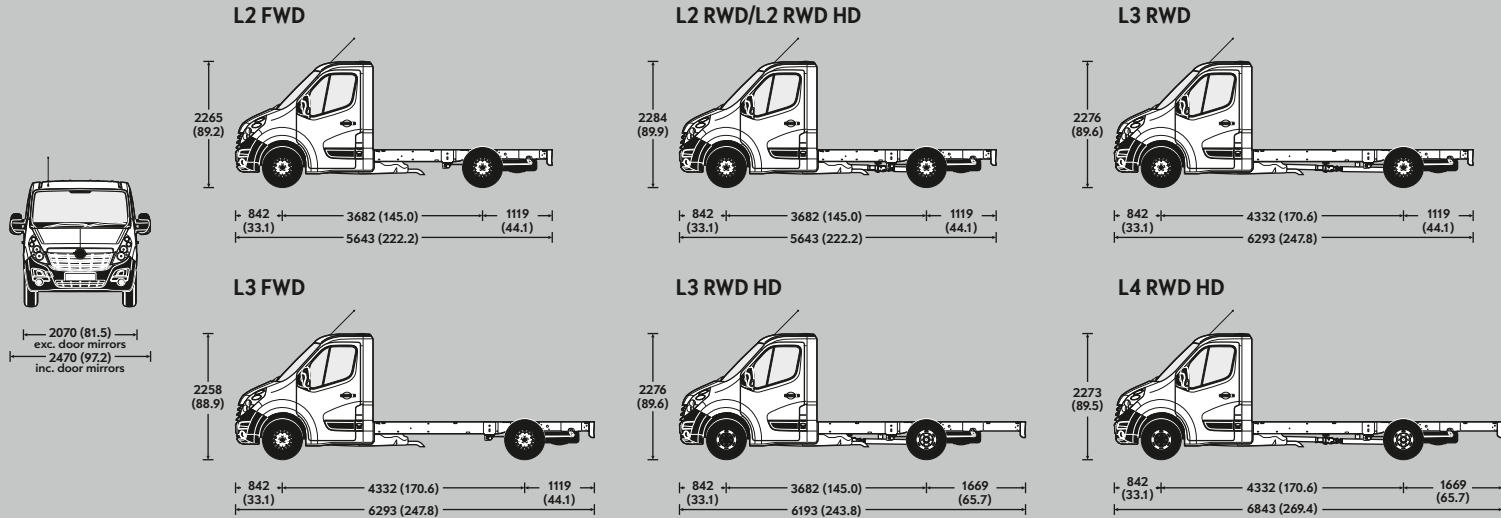

Dimensions mm (inches). Maximum heights shown (unladen).

WEIGHTS KG – CHASSIS CAB

GVW		L2	L3	L4
3500 FWD**	Minimum Mass*	1784	1810	–
	Payload and Body Allowance*	1756	1730	–
3500 RWD	Minimum Mass*	1928	1979	–
	Payload and Body Allowance*	1612	1561	–
3500 RWD HD	Minimum Mass*	2095	2103	2133
	Payload and Body Allowance*	1445	1437	1407
4500 RWD HD	Minimum Mass*	2095	2095	2133
	Payload and Body Allowance*	2445	2445	2407

* = For definitions please refer to Glossary of Terms.

** = BiTurbo models add 9kg-10kg to the vehicle weight with a corresponding reduction in payload.

The weight of any fitted conversion body will have to be deducted from these figures to establish actual payload and is subject to correct weight distribution. Variations from the recommended dimensions or weights may affect the vehicle's overall centre of gravity and stability. From 29 April 2013 conversion of N1 vehicles was affected by changes to type approval – for further information refer to the RSA website (N2 vehicles were affected from 29 October 2014).

FUEL ECONOMY AND EMISSIONS – CHASSIS CAB

	Fuel economy litres/100km [#]			CO ₂ emissions (g/km) [#]
	Urban driving	Extra-urban driving	Combined figure	
L2/L3 FWD				
3500 2.3CDTi (110PS)	9.3	7.5	8.2	212
3500 2.3CDTi (130PS)	9.3	7.5	8.2	212
3500 2.3CDTi BiTurbo (145PS) S/S	7.9	7.1	7.4	192
L2/L3 RWD				
3500 2.3CDTi BiTurbo (130PS)	9.3	8.7	9.0	232
3500 2.3CDTi BiTurbo (145PS) S/S	8.2	8.1	8.2	212
L2/L3/L4 RWD HD				
3500 HD 2.3CDTi BiTurbo (130PS)	9.6	9.2	9.3	242
3500 HD 2.3CDTi BiTurbo (145PS) S/S	8.5	8.6	8.6	222

[#]Fuel consumption information is official government environmental data, tested in accordance with the relevant EU directive. Official EU-regulated test data is provided for comparison purposes and actual performance will depend on driving style, road conditions and other non-technical factors.

S/S = Start/Stop.

MOVANO CHASSIS CREW CAB

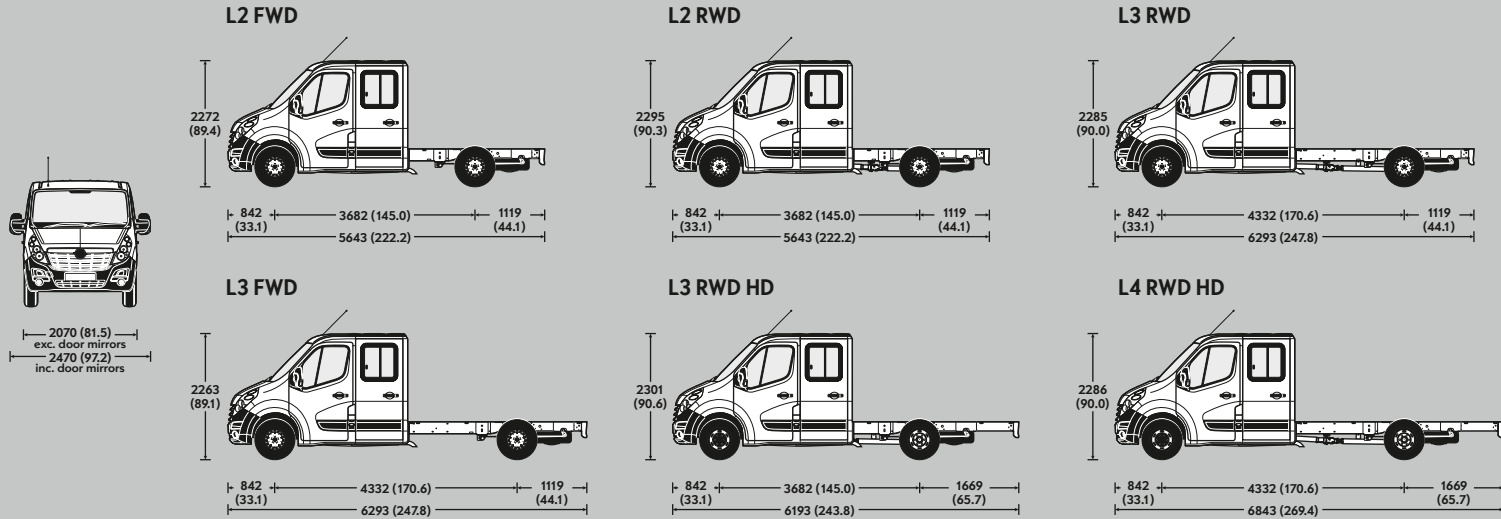

Dimensions mm (inches). Maximum heights shown (unladen).

WEIGHTS KG – CHASSIS CREW CAB

GVW		L2	L3	L4
3500 FWD**	Minimum Mass*	1990	2034	–
	Payload and Body Allowance*	1550	1506	–
3500 RWD	Minimum Mass*	2164	2197	–
	Payload and Body Allowance*	1376	1343	–
3500 RWD HD	Minimum Mass*	–	2283	2352
	Payload and Body Allowance*	–	1257	1188
4500 RWD HD	Minimum Mass*	–	2283	2352
	Payload and Body Allowance*	–	2257	2188

* = For definitions please refer to Glossary of Terms.

** = BiTurbo models add 9kg-10kg to the vehicle weight with a corresponding reduction in payload.

The weight of any fitted conversion body will have to be deducted from these figures to establish actual payload and is subject to correct weight distribution. Variations from the recommended dimensions or weights may affect the vehicle's overall centre of gravity and stability. From 29 April 2013 conversion of N1 vehicles was affected by changes to type approval – for further information refer to the RSA website (N2 vehicles were affected from 29 October 2014).

FUEL ECONOMY AND EMISSIONS – CHASSIS CREW CAB

	Fuel economy litres/100km [#]			CO ₂ emissions (g/km) [#]
	Urban driving	Extra-urban driving	Combined figure	
L2/L3 FWD				
2.3CDTi (130PS)	9.3	7.5	8.2	212
2.3CDTi BiTurbo (145PS) S/S	7.9	7.1	7.4	192
L2/L3 RWD				
2.3CDTi BiTurbo (130PS)	9.3	8.7	9.0	232
2.3CDTi BiTurbo (145PS) S/S	8.2	8.1	8.2	212
L3/L4 RWD HD				
2.3CDTi BiTurbo (130PS)	9.6	9.2	9.3	242
2.3CDTi BiTurbo (145PS) S/S	8.5	8.6	8.6	222

[#]Fuel consumption information is official government environmental data, tested in accordance with the relevant EU directive. Official EU-regulated test data is provided for comparison purposes and actual performance will depend on driving style, road conditions and other non-technical factors.

S/S = Start/Stop.

MOVANO PLATFORM CAB

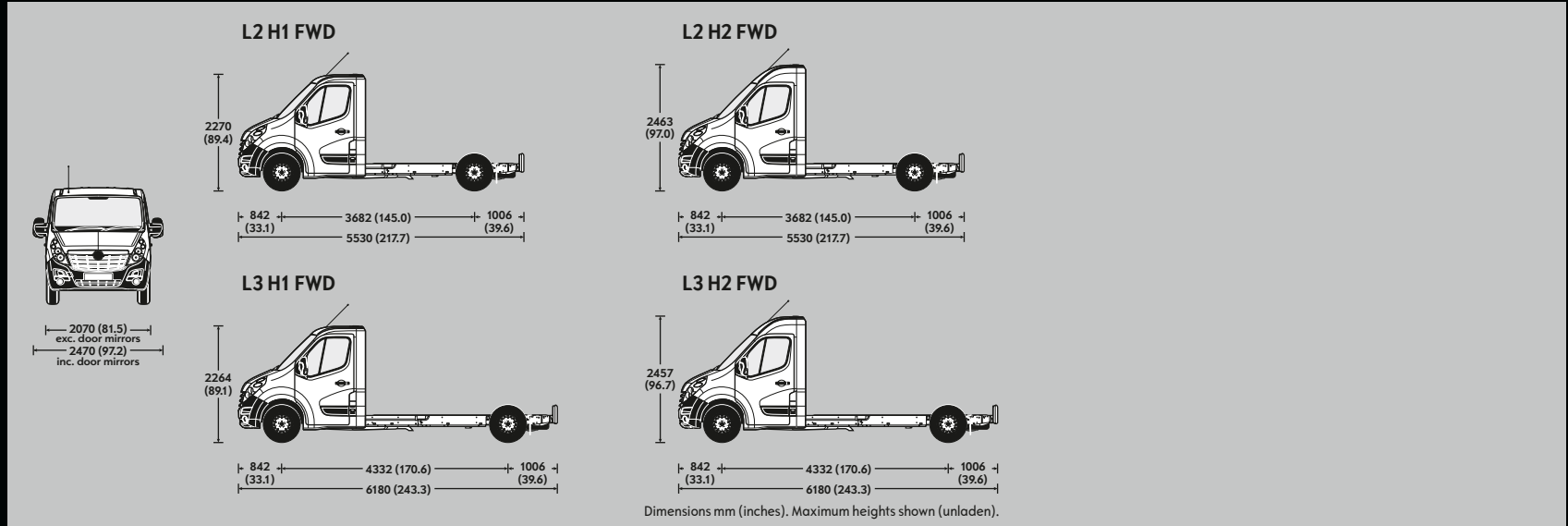

WEIGHTS KG – PLATFORM CAB

GVW		L2 H1	L2 H2	L3 H1	L3 H2
3500 FWD**	Minimum Mass*	1697	1711	1719	1735
	Payload and Body Allowance*	1843	1829	1821	1805

* = For definitions please refer to Glossary of Terms.

** = BiTurbo models add 9-10kg to the vehicle weight with a corresponding reduction in payload.

The weight of any fitted conversion body will have to be deducted from these figures to establish actual payload and is subject to correct weight distribution. Variations from the recommended dimensions or weights may affect the vehicle's overall centre of gravity and stability. From 29 April 2013 conversion of N1 vehicles was affected by changes to type approval – for further information refer to the RSA website (N2 vehicles were affected from 29 October 2014).

FUEL ECONOMY AND EMISSIONS – PLATFORM CAB

L2 H1/L3 H1/L2 H2/L3 H2 FWD	Fuel economy litres/100km [#]			CO ₂ emissions (g/km) [#]
	Urban driving	Extra-urban driving	Combined figure	
3500 2.3CDTi (110PS)	9.0	7.2	7.9	207
3500 2.3CDTi (130PS)	9.0	7.2	7.9	207
3500 2.3CDTi BiTurbo (145PS) S/S	7.9	7.1	7.4	192

[#]Fuel consumption information is official government environmental data, tested in accordance with the relevant EU directive. Official EU-regulated test data is provided for comparison purposes and actual performance will depend on driving style, road conditions and other non-technical factors.

S/S = Start/Stop.

MOVANO TIPPER / TIPPER CREW CAB

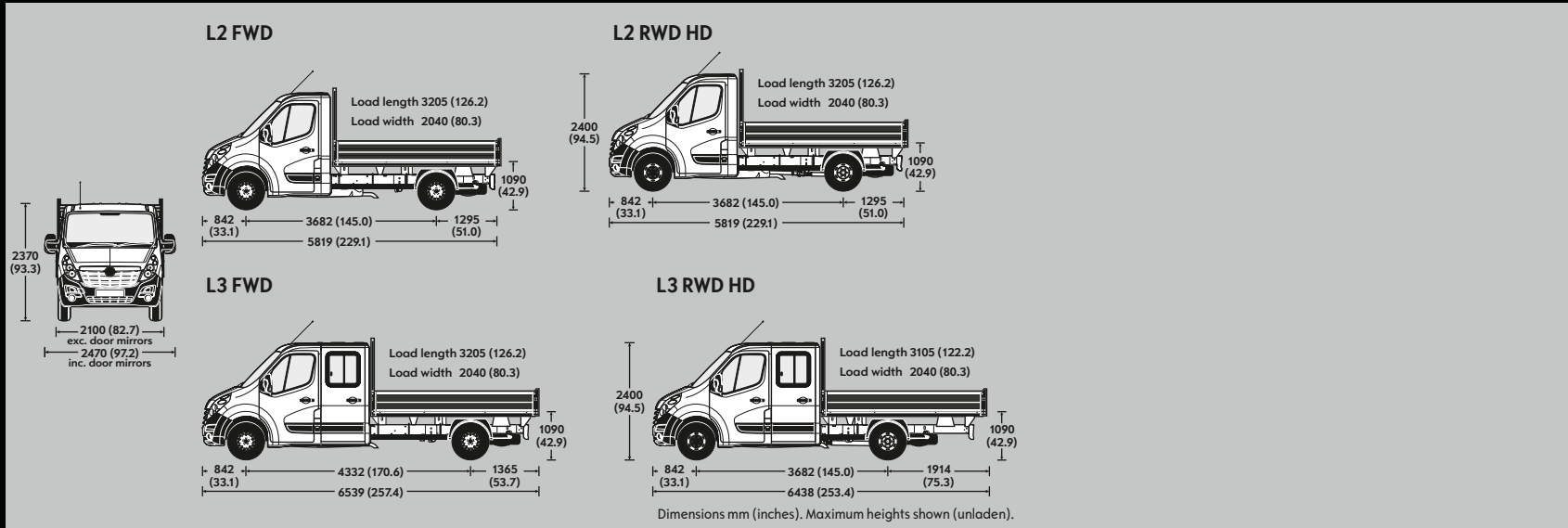

WEIGHTS KG – TIPPER / TIPPER CREW CAB

GVW		L2	L3
3500 FWD**	Minimum Mass*	2381	2511
	Payload*	1159	1029
3500 RWD HD	Minimum Mass*	2661	2773
	Payload*	879	767
4500 RWD HD	Minimum Mass*	2661	2773
	Payload*	1879	1767

* = For definitions please refer to Glossary of Terms.

** = BiTurbo models add 9-10kg to the vehicle weight with a corresponding reduction in payload.

FUEL ECONOMY AND EMISSIONS – TIPPER / TIPPER CREW CAB

	Fuel economy litres/100km [#]			CO ₂ emissions (g/km) [#]
	Urban driving	Extra-urban driving	Combined figure	
L2 FWD				
3500 2.3CDTi (130PS)	9.0	7.2	7.9	207
3500 2.3CDTi BiTurbo (145PS) S/S	7.8	7.0	7.3	189
L2 RWD HD				
3500 HD 2.3CDTi BiTurbo (130PS)	9.6	9.2	9.3	242
3500 HD 2.3CDTi BiTurbo (145/163PS) S/S	8.5	8.6	8.6	222
L3 FWD				
3500 2.3CDTi (130PS)	9.2	7.4	8.1	210
3500 2.3CDTi BiTurbo (145PS) S/S	7.8	7.0	7.3	189

[#]Fuel consumption information is official government environmental data, tested in accordance with the relevant EU directive. Official EU-regulated test data is provided for comparison purposes and actual performance will depend on driving style, road conditions and other non-technical factors.

S/S = Start/Stop.

MOVANO DROPSIDE

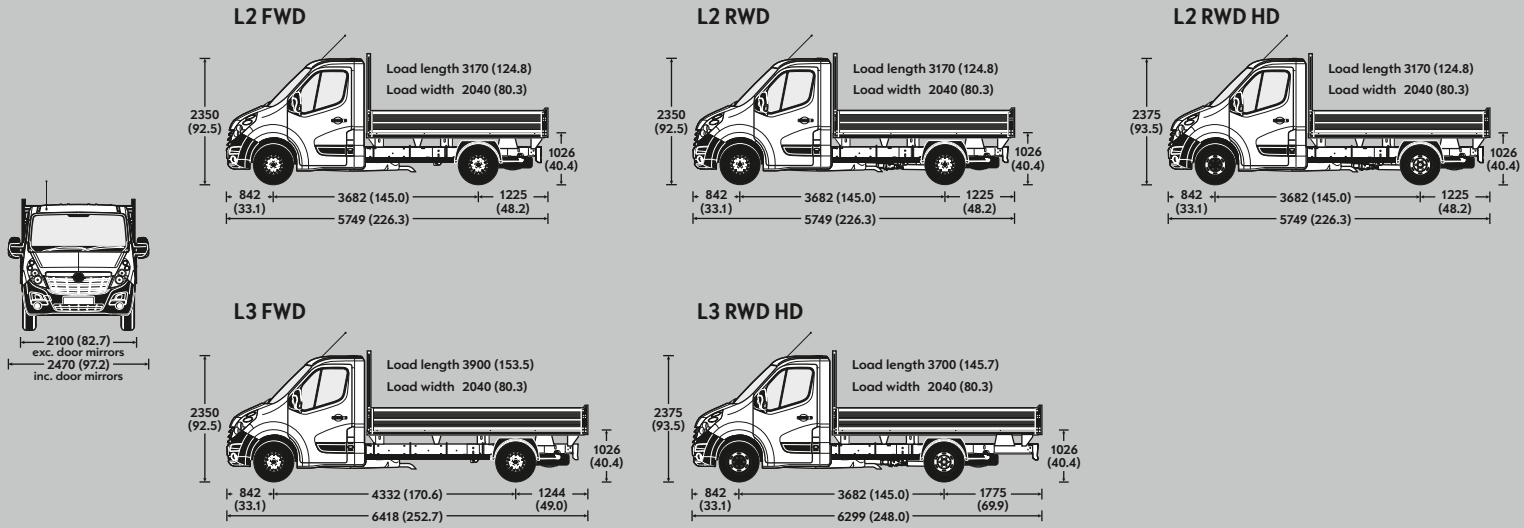

Dimensions mm (inches). Maximum heights shown (unladen).

WEIGHTS KG – DROPSIDE

GVW		L2	L3
3500 FWD**	Minimum Mass*	2156	2228
	Payload*	1384	1312
3500 RWD	Minimum Mass*	2356	–
	Payload*	1184	–
3500 RWD HD	Minimum Mass*	2447	2491
	Payload*	1093	1049
4500 RWD HD	Minimum Mass*	2447	2496
	Payload*	2093	2044

* = For definitions please refer to Glossary of Terms.
 ** = BiTurbo models add 9-10kg to the vehicle weight with a corresponding reduction in payload.

FUEL ECONOMY AND EMISSIONS – DROPSIDE

	Fuel economy litres/100km [#]			CO ₂ emissions (g/km) [#]
	Urban driving	Extra-urban driving	Combined figure	
L2 FWD				
3500 2.3CDTi (130PS)	8.9	7.1	7.8	204
3500 2.3CDTi BiTurbo (145PS) S/S	7.6	6.7	7.0	183
L3 FWD				
3500 2.3CDTi (130PS)	9.0	7.2	7.9	207
3500 2.3CDTi BiTurbo (145PS) S/S	7.8	6.8	7.2	186
L2 RWD				
3500 2.3CDTi (130PS)	9.3	8.7	9.0	232
3500 2.3CDTi BiTurbo (145PS) S/S	8.2	8.1	8.2	212
L2/L3 RWD HD				
3500 HD 2.3CDTi BiTurbo (130PS)	9.6	9.2	9.3	242
3500 HD 2.3CDTi BiTurbo (145PS) S/S	8.5	8.6	8.6	222

[#]Fuel consumption information is official government environmental data, tested in accordance with the relevant EU directive. Official EU-regulated test data is provided for comparison purposes and actual performance will depend on driving style, road conditions and other non-technical factors.
 S/S = Start/Stop.

MOVANO DROPSIDE CREW CAB

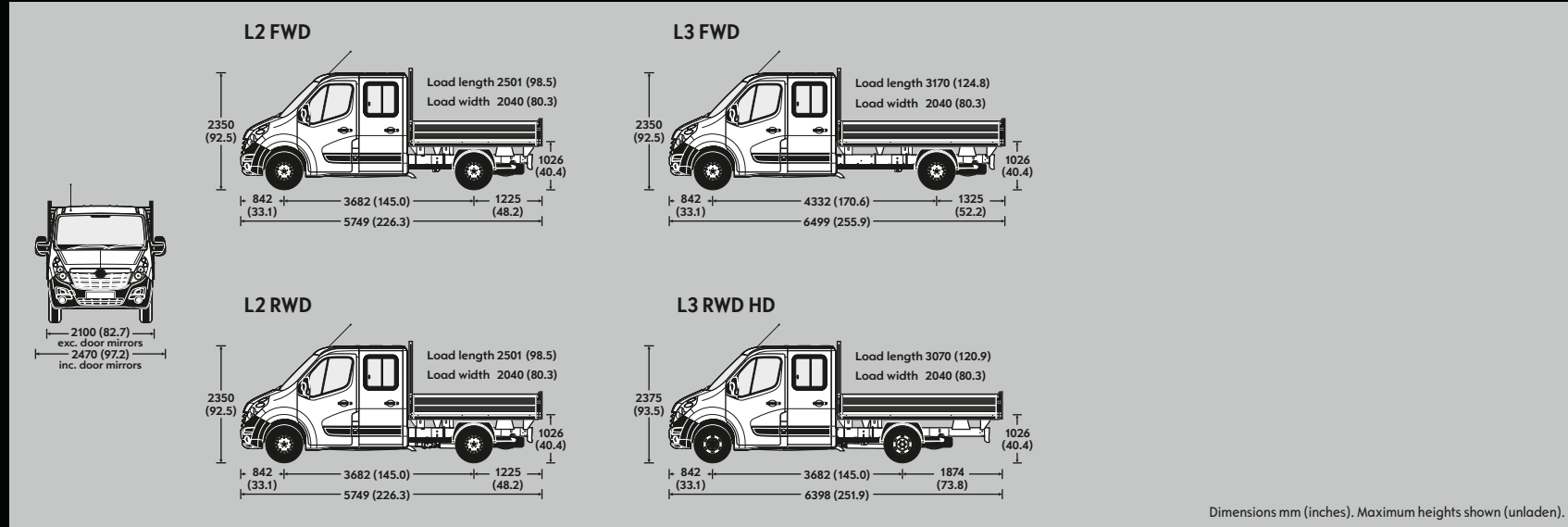

WEIGHTS KG – DROPSIDE CREW CAB

GVW		L2	L3
3500 FWD**	Minimum Mass*	2313	2384
	Payload*	1227	1156
3500 RWD	Minimum Mass*	2471	–
	Payload*	1069	–
3500 RWD HD	Minimum Mass*	–	–
	Payload*	–	–
4500 RWD HD	Minimum Mass*	–	2642
	Payload*	–	1898

* = For definitions please refer to Glossary of Terms.

** = BiTurbo models add 9-10kg to the vehicle weight with a corresponding reduction in payload.

FUEL ECONOMY AND EMISSIONS – DROPSIDE CREW CAB

	Fuel economy litres/100km [#]			CO ₂ emissions (g/km) [#]
	Urban driving	Extra-urban driving	Combined figure	
L2/L3 FWD				
3500 2.3CDTi (130PS)	9.0	7.2	7.9	207
3500 2.3CDTi BiTurbo (145PS) S/S	7.8	6.8	7.2	186
L2 RWD				
3500 2.3CDTi (130PS)	9.3	8.7	9.0	232
3500 2.3CDTi BiTurbo (145PS) S/S	8.2	8.1	8.2	212

[#]Fuel consumption information is official government environmental data, tested in accordance with the relevant EU directive. Official EU-regulated test data is provided for comparison purposes and actual performance will depend on driving style, road conditions and other non-technical factors.

S/S = Start/Stop.

MOVANO BOX VAN

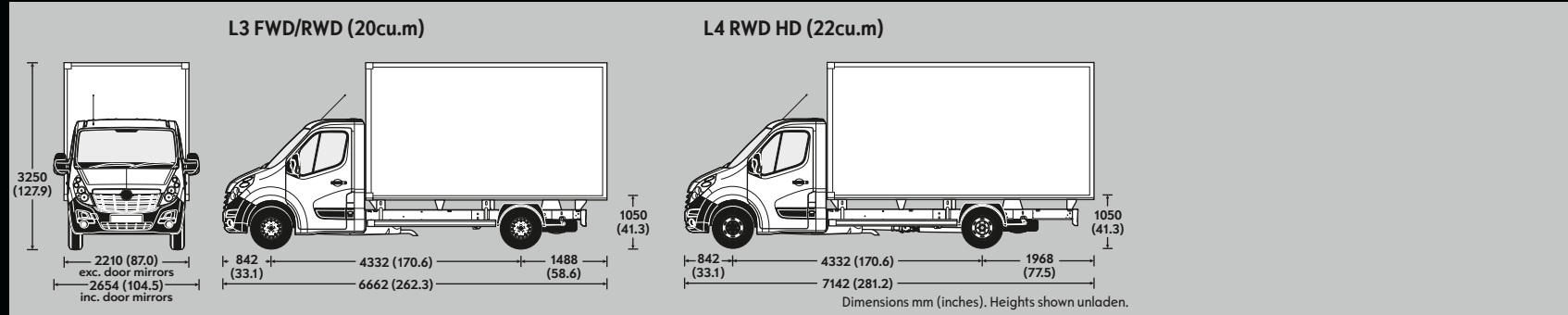

LOADSPACE DIMENSIONS MM (INCHES) – BOX VAN

	L3 20cu.m FWD/RWD	L4 22cu.m RWD
Maximum internal length	4100 (161.4)	4580 (180.3)
Maximum internal width	2150 (84.6)	2150 (84.6)
Maximum internal height	2200 (86.6)	2200 (86.6)

LOADSPACE VOLUME CU.M (CU.FT.) – BOX VAN

VDA method	19.4 (685.1)	21.7 (766.3)
------------	--------------	--------------

WEIGHTS KG – BOX VAN

GVW		L3	L4 (22cu.m)
3500 FWD	Minimum Mass*	2400	–
	Payload*	1140	–
3500 RWD	Minimum Mass*	2560	–
	Payload*	980	–
3500 RWD HD	Minimum Mass*	–	2760
	Payload*	–	780

* = For definitions please refer to Glossary of Terms.

FUEL ECONOMY AND EMISSIONS – BOX VAN

	Fuel economy litres/100km [#]			CO ₂ emissions (g/km [#])
	Urban driving	Extra-urban driving	Combined figure	
L3 FWD 20cu.m				
3500 2.3CDTi (130PS)	9.2	7.4	8.1	210
3500 2.3CDTi BiTurbo (145PS) S/S	7.8	7.0	7.3	189
L3 RWD 20cu.m				
3500 2.3CDTi BiTurbo (130PS)	9.3	8.7	9.0	232
3500 2.3CDTi BiTurbo (145PS) S/S	8.2	8.1	8.2	212
3500 2.3CDTi BiTurbo (163PS) S/S	8.2	8.1	8.2	212
L4 RWD HD 22cu.m				
3500 HD 2.3CDTi BiTurbo (130PS)	9.6	9.2	9.3	242
3500 HD 2.3CDTi BiTurbo (145PS) S/S	8.5	8.6	8.6	222

#Fuel consumption information is official government environmental data, tested in accordance with the relevant EU directive. Official EU-regulated test data is provided for comparison purposes and actual performance will depend on driving style, road conditions and other non-technical factors.

S/S = Start/Stop.

Plated weight

The maximum weight to which a vehicle or an axle may be loaded, determined either by the design of the components or by legislation. All commercial vehicles must carry a manufacturer's 'plate' showing the vehicle and axle gross 'plated weights'. It is an offence to drive a vehicle in a condition where any of these weights are exceeded.

Minimum Mass

Minimum Mass ('Mass in running order' on Certificate of Conformity and 'Mass in Service' on V5C form) is defined according to European Type Approval and include all fluids, tools, 90% fuel load and driver (75kg). It is minimum mass for this variant and does not consider local specification/trim or deletable options (specific to Movano). Weights are also subject to manufacturing tolerances (EU Legislation allows 5% tolerance).

Gross Vehicle Weight (GVW)

The total permissible weight of a vehicle including payload and passengers, as shown on the manufacturer's plate.

Gross Combination Weight (GCW)

The maximum permissible weight of a vehicle, including payload and passengers, combined with the total weight of any trailer it is towing. The maximum GCW weight limit is quoted on the vehicle plate and must not be exceeded.

Payload

The total permissible weight that can be carried without exceeding the vehicle's plated weight. Payloads do not include driver but do take into consideration specification: Movano models include Ireland/UK specification (10kg) and deletable options such as Bulkhead (25kg); Sliding Doors (30kg each) and Spare Wheel (25kg). Weights are also subject to manufacturing tolerances (EU Legislation allows 5% tolerance). Payload does not consider any additional options that a customer may order.

Roof Load

Roof load should not exceed 200kg including the weight of the roof rack/carrier. H3 models are not permitted to carry roof loads.

Maximum towing weight

The maximum weight of any trailer and its load which may be towed within the limit of the vehicle's plated Gross Combination Weight (GCW). It is based on the ability of the vehicle – at full GCW – to restart on a 12% gradient, which is approximately 1 in 8.3, at sea level. At altitudes above 1500 metres, the engine output may drop with a corresponding reduction in towing capability. It is the operator's responsibility to ensure that the trailer noseweight does not cause the rear axle plated weight of the towing vehicle to be exceeded. Always fit Opel towing attachments and accessories available from your Opel Commercial Vehicle retailer. They are designed specifically for Opel models and carry a 12-month warranty.

Conversions

The weight of any fitted conversion body will have to be deducted from these figures to establish actual payload and is subject to correct weight distribution. Variations from the recommended dimensions or weights may affect the vehicle's overall centre of gravity and stability. From 29 April 2013 conversion of N1 vehicles was affected by changes to type approval – for further information refer to the RSA website (N2 vehicles were affected from 29 October 2014).

- Every Movano base vehicle comes with: A three-year vehicle warranty consisting of a one-year/unlimited mileage manufacturer's warranty and a second and third year manufacturer's warranty with a 150,000km limitation
- Opel Assistance for 12 months from first registration

Opel Service.

Commercial vehicle dealer network.

A network of nationwide Opel Ireland commercial vehicle dealers, including dedicated heavy van specialists responsible for Vivaro and Movano, offer sales support and the expert service and maintenance know how to keep your business moving.

Europe-wide Customer Service.

Throughout Europe, more than 6,000 Opel repair workshops are ready to provide professional and punctual service. As you'd expect, they'll repair your vehicle to the highest standards. More unusually, perhaps, they'll tell you exactly what's been done and why, and they will show any costs involved clearly and concisely.

New Vehicle Warranty.

3-year/150,000km. This warranty applies to any new Opel commercial vehicle for a period of 3 years or 150,000km (whichever occurs sooner) from the day on which it was either registered for the first time or delivered to the customer by the dealer, depending on which date comes first.

Opel Roadside Assistance.

This free-of-charge mobility service is valid for all new Opel vehicles during the first year after the date on which they were first registered or delivered to the customer by the dealer, depending on which date comes first. No matter where you are, the Opel Assistance is there to help. In more than 40 European countries – round the clock. Offering services such as breakdown assistance, towing services, rental car, hotel accommodation or the organisation of

onward transportation, e.g. via rail or air (please see programme conditions).

12-year Anti-Perforation Warranty.

Opel provides you with a reliable long-term warranty against perforation, provided you have your vehicle serviced and all necessary inspections performed according to the service booklet.

2-year Warranty for Opel Batteries.

With a 2-year warranty for service-installed Opel original batteries your starting problems are over – even in the coldest winter.

Parts and Accessories Service.

Opel parts and accessories are available at your local Opel Shop, where you'll find everything to make your vehicle more comfortable or to meet your individual needs, as well as expert advice.

Opel on the Internet.

Need instant information? At www.opel.ie you can access a wealth of information on all commercial vehicle, services, and accessories. Get online for Opel news and product updates.

Recycling.

Information about Design for Recycling, Take-Back points for End of Life Vehicles (ELVs) and the recycling of ELVs can be found on the Opel website www.opel.ie

In case of any questions, please ask your Opel dealer. More information can be found at www.opel.ie

www.opel.ie

Every effort has been made to ensure that the contents of this publication were accurate and up-to-date at the time of going to press (September 2017). Opel vehicles are equipped with components manufactured by various Opel operating units and outside suppliers. The Company reserves the right to change specifications and withdraw products from sale without notice. Any such alterations will be notified to Opel dealers at the earliest opportunity; please consult your local dealer for the latest information. The specifications detailed within this brochure are not necessarily applicable to alternative models such as Special Editions. Details of any such models will be contained in specific literature or found on the Opel website. The colours reproduced in this brochure may vary slightly from the actual paint colour or trim material due to the limitations of the printing process. Please note that Opel dealers are not the agents of Opel Automobile Ireland Limited and are not authorised to bind the Company by any specific or implied undertaking or representation. It is advisable to ensure that your motor insurance policy provides adequate cover for additional fitted options and accessories. As part of Opel's policy of environmental care, this brochure is printed on paper manufactured using Elemental Chlorine Free pulps from specially farmed, sustainable timber resources. All rights reserved. No part of this publication may be reproduced in any form or by any means, without the prior written permission of Opel Automobile Ireland Limited.