



ALL-NEW PEUGEOT 2008 SUV

PRICES, EQUIPMENT, OPTIONS & TECHNICAL SPECIFICATIONS

FEBRUARY 2020: E & OE



PEUGEOT

STANDARD SPECIFICATION

Safety & Security

- ABS (Anti-lock Braking System) with EBD (Electronic Braking Distribution) and EBA (Emergency Braking Assistance)
- Airbags: Driver and front passenger airbags (includes passenger airbag deactivation function)
- Airbags: Front and rear curtain airbags
- Automatic door locking when moving off
- Automatic hazard light activation upon heavy brake application
- Child locking functionality on rear doors
- Deadlocking
- Electronic code immobiliser
- ESP (Electronic Stability Programme) with Hill Start Assist
- Front optimised safety headrests and rear retractable headrests (x3), height-adjustable
- Front three-point retractable seatbelts, with force limiters
- Front and rear disc brakes
- Gear Shift Indicator (manual version only)
- Headlights 'left on' audible warning
- Isofix child seat fittings (x2) in the second row
- PEUGEOT Connect SOS and Assistance
- Programmable cruise control and speed limiter
- Lane Keeping Assist
- Speed limit recognition and recommendation
- Driver attention warning
- Seatbelt unfastened on the move with audible and visual alert for front and rear seats
- Space saver spare wheel (Petrol/Diesel versions)
- Puncture repair kit (EV versions)
- Tyre pressure sensors
- Exterior temperature indicator with ice warning
- EV versions come with 7.4kW monophasic on board charger

Lighting & Visibility

- Rear reversing lights
- Rear full LED 3D PEUGEOT signature 'Claw Effect' lights (with daylight function)
- Visibility pack: automatic headlights
- Visibility pack: 'follow me home' headlights
- Visibility pack: automatic windscreen wipers

Comfort and Convenience

- Electric power steering with reach and rake adjustable steering column
- Front windscreen wiper with 'Magic Wash' cleaning system
- Map pockets on front seat backs
- Multifunction trip computer
- 'One-touch' electric front windows with pinch protection
- PEUGEOT i-Cockpit®: compact steering wheel
- PEUGEOT i-Cockpit®: 7.0" capacitive colour touchscreen
- Push button start
- Tailgate with heated rear windscreen & wiper blade

Interior Features

- Dashboard, front and rear door panel finish: Carbon effect
- Rear windscreen wiper triggered automatically in reverse gear
- Gear lever – automatic in full grain leather and satin chrome
- Gear lever – manual in satin chrome (6 speed gearbox)
- 'Piano' keys: Gloss black plated toggle switches to access main functions of the vehicle
- Seating: 1/3 – 2/3 folding seat
- Seating: driver and front passenger seat manual adjustment (longitudinal and back rest angle)

In Car Entertainment

- Bluetooth® telephone facility
- DAB Radio (Digital Audio Broadcasting)
- Mirror Screen®: with Apple CarPlay™ and Android Auto connectivity
- Smartphone docking station
- Voice recognition (radio, navigation and telephony features)
- 6-Speaker radio, MP3 compatible
- 12v socket

Exterior Features

- Body-colour exterior door handles
- Gloss black rear cluster connecting strip
- Model designation badges front and rear



ACTIVE

(Available as Petrol, Diesel and EV)



Active Specification

EXTERIOR FEATURES

- 16" alloy wheels
- Door mirror shells: Colour coded
- Radiator grille: Chrome chequered
- Radiator grille: body-colour chequered and gloss black edge trim (EV versions)
- Colour coded rear spoiler
- Dichroic badging including front lion, 'e' monogram on C-pillar and tailgate (EV versions)

COMFORT AND CONVENIENCE

- Manual air conditioning
- Automatic air conditioning (EV versions)
- Pre-heating functionality (EV versions)
- Low centre console
- High centre console with 2 cup holders (EV versions)
- Central front armrest with storage compartment (EV versions)
- Electric and heated door mirrors
- Manual rear view mirror
- Manual parking brake
- Electric parking brake (EV versions)
- Parking sensors – rear
- PEUGEOT i-Cockpit® with 3.5" instrument panel display
- Visiopark 180-Colour reversing camera
- eTSR (extended traffic sign recognition)

INTERIOR FEATURES

- Leather steering wheel
- Seating: driver and front passenger comfort seats
- Seating: Tri-material 'Leorki' and 'Rimini' cloth seat trim with orange double stitch detail

SAFETY AND SECURITY

- Active Safety Brake (pedestrians)

LIGHTING AND VISIBILITY

- Eco LED headlights
- LED daytime running lights: 3-Claw Headlight with distinctive 'Tooth' design
- LED foglights with cornering function

IN CAR ENTERTAINMENT

- USB Socket (x1) front
- USB Socket (x2) front including 1 USB-C (EV versions)
- USB Socket (x2) rear (EV versions)

ALLURE

(Available as Petrol, Diesel and EV)



Active Specification +

EXTERIOR FEATURES

- 17" diamond cut alloy wheels
- Gloss black B-pillar
- Gloss black longitudinal roof bars
- Rear bumper with gloss black finish

INTERIOR FEATURES

- Seating: Tri-material 'Curitiba' leather effect and 'Isabella' cloth seat trim with light blue double stitch detail

COMFORT AND CONVENIENCE

- Automatic air conditioning
- High centre console with 2 cup holders
- Central front armrest with storage compartment
- Electric, heated and power folding door mirrors
- Passenger seat height adjustment
- Parking sensors – front & rear
- Electrochrome rear view mirror
- Electric parking brake
- PEUGEOT 3D i-Cockpit®: Configurable 3D head-up instrument panel
- Dark tinted rear side and tailgate windows
- Modular boot floor

IN CAR ENTERTAINMENT

- USB Socket (x2) front including 1 USB-C
- USB Socket (x2) rear



NEW PEUGEOT 2008 SUV: STANDARD EQUIPMENT BY VERSION - GT LINE & GT

GT LINE

(Available as Petrol, Diesel and EV)



Allure Specification +

COMFORT AND CONVENIENCE

- Frameless Electrochrome rear view mirror
- Heated front seats
- PEUGEOT 3D i-Cockpit®: 10" capacitive colour touchscreen 3D Navigation

EXTERIOR FEATURES

- Door mirror shells: Gloss Black
- GT Line model designation badging (Petrol/Diesel versions)
- Radiator grille: Dark chrome chequered and gloss black edge trim
- Rear lower bumper gloss black 'diffuser effect' trim
- Exhaust pipe: twin chrome right hand side (Petrol/Diesel versions)
- Diamond Black roof
- Diamond Black rear spoiler

SAFETY AND SECURITY

- Active Safety Brake (night function, cyclist, pedestrians)

IN CAR ENTERTAINMENT

- Smartphone charging plate

INTERIOR FEATURES

- Seating: Tri-material 'Capy' leather effect and 'Isabella' cloth seat trim with lime green double stitch detail
- Mistral full-grain perforated leather steering wheel with Aikinite stitch detail and satin chrome 'GT Line' emblem
- Lime green contrast stitching to armrest, front centre console, door panels and dashboard fascia 8-colour personalisable ambient lighting

LIGHTING AND VISIBILITY

- Full LED headlights with Smartbeam Assist
- LED daytime running lights: 3-Claw Headlight with distinctive 'Tooth' design

GT

(Available as EV)



GT Line Specification +

EXTERIOR FEATURES

- Exhaust pipe: double chrome (Petrol Version)
- 18" diamond cut dark finish alloy wheels

SAFETY AND SECURITY

- Adaptive cruise control with Stop & Go function
- Lane positioning assist
- Active blind spot monitoring

INTERIOR FEATURES

- Seating: Tri-material grey Alcantara® and 'Isabella' cloth seat trim with lime green and blue stitch detail (Petrol Version)
- Seating: Tri-material grey Alcantara® and 'Isabella' cloth seat trim with lime green and blue stitch detail (EV Version)





IN CAR ENTERTAINMENT

- Smart Phone Charging Plate



Images used for illustration purposes only. Wheel trims vary according to market. Please refer to alloy wheel options.

NEW PEUGEOT 2008 SUV: PRICE LIST (PRICES VALID FROM 14/02/2020)

	Model Description	Fuel Type	Speed	WLTP Co2	Tax Band	Annual Road Tax	RRSP*
 ACTIVE	1.2 Puretech 100bhp	Petrol	6-Speed	125	A3	€190	€23,900
	1.2 Puretech 130bhp	Petrol	6-Speed	130	A3	€190	€25,400
	1.2 Puretech 130bhp Auto	Petrol	8-Speed	138	A3	€190	€27,400
	1.5 BlueHDI 100bhp	Diesel	6-Speed	118	A2	€180	€25,900
	Electric 50 kWh 136^	Electric	8-Speed	0	A0	TBC	TBC
 ALLURE	1.2 Puretech 100bhp	Petrol	6-Speed	127	A3	€190	€25,850
	1.2 Puretech 130bhp	Petrol	6-Speed	132	A3	€190	€27,350
	1.2 Puretech 130bhp Auto	Petrol	8-Speed	140	A3	€190	€29,350
	1.2 Puretech 155bhp Auto	Petrol	8-Speed	141	A4	€200	€30,600
	1.5 BlueHDI 100bhp	Diesel	6-Speed	120	A2	€180	€27,850
	Electric 50 kWh 136^	Electric	8-Speed	0	A0	TBC	TBC
 GT LINE	1.2 Puretech 100bhp	Petrol	6-Speed	124	A3	€190	€28,380
	1.2 Puretech 130bhp	Petrol	6-Speed	133	A3	€190	€29,880
	1.2 Puretech 130bhp Auto	Petrol	8-Speed	140	A3	€190	€31,880
	1.2 Puretech 155bhp Auto	Petrol	8-Speed	141	A4	€200	€33,130
	1.5 BlueHDI 100bhp	Diesel	6-Speed	120	A2	€180	€30,380
	Electric 50 kWh 136^	Electric	8-Speed	0	A0	TBC	TBC
 GT	1.2 Puretech 155bhp Auto	Petrol	8-Speed	141	A4	€200	€34,950
	Electric 50 kWh 136^	Electric	8-Speed	0	A0	TBC	TBC

* Dealer delivery related charges, metallic paint and tyre recycling levy not included

** Includes SEAI grant and VRT rebate

ALL-NEW PEUGEOT 2008 SUV 100% ELECTRIC WITHOUT COMPROMISE

LIVE THE POWER OF CHOICE

The all-new PEUGEOT 2008 SUV is not only available with a choice of petrol or diesel powertrains but is also available as an 100% electric vehicle.

The all-new PEUGEOT e-2008 SUV features the following key elements:

TECHNICAL

Electric 50 kWh 136hp motor

The all-new PEUGEOT e-2008 SUV offers a lively and stimulating drive thanks to its 100% electric powertrain. You benefit from immediate reactivity with 260Nm of torque from 0kph. The silent engine offers a serene* drive without vibration.

e-CMP platform

The new e-CMP platform has been developed to incorporate a high voltage battery whilst preserving space on board and boot volume. Particular attention was given to weight reduction and balance to make sure the driving experience in the all-new PEUGEOT 2008 SUV is as rewarding as possible.

Range 310km WLTP

Charging flexibility with 3 modes available:

Domestic (AC): 10A /3kW from a regular socket, full charge in 24 hours (accessory cable needed).

Fast (AC) 32A / 7kW from a Wall Box, full charge in 7.5 hours.

Rapid (DC) 100kW from a dedicated public terminal, 80% charged in 30 minutes.

USAGE

3 driving modes

In the all-new PEUGEOT e-2008 SUV you will be able to chose between 3 driving modes:

- Sport: priority given to performance (0-100kph in 8.1s)
- Normal: daily usage
- Eco: priority given to range

2 braking modes

The all-new PEUGEOT e-2008 SUV also benefits from 2 braking modes that helps you make the best of your range:

- Moderate: sensation similar to an ICE engine
- Emphasised: deceleration controlled with accelerator pedal

Specific animations

The all-new PEUGEOT e-2008 SUV features specific technological animations and menus on the touch-screen so that you can access easily all the information needed.

*Take care when driving as other road users may not be accustomed to electric vehicles. All-new PEUGEOT e-2008 SUV is fitted with an acoustic vehicle alerting system.

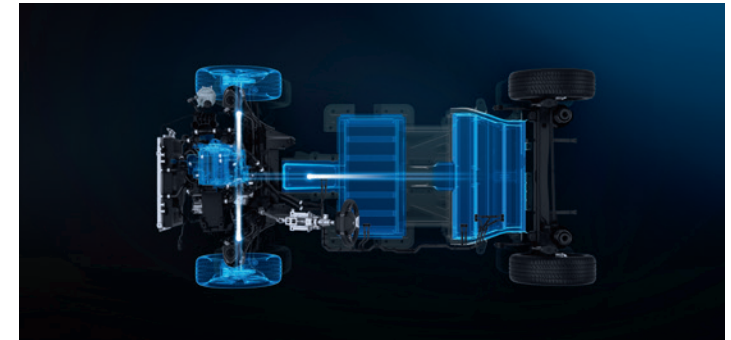

MYPEUGEOT® APPLICATION

- **Charge management:** Control, plan, launch and check the vehicle's charge remotely
- **Climate preset:** Remotely plan and control the heating or air conditioning in the interior of your car
- **e-Coaching:** Consumption logs and statistics

EXTERIOR STYLING

The all-new PEUGEOT e-2008 SUV comes with distinctive and exclusive touches, a body coloured chequered front grille with gloss black edge trim.

The Lion logo featuring a specific dichroic treatment which changes colour from different angles depending on the exterior lighting.

An 'e' monogram on the front side panel and tailgate.



NEW PEUGEOT 2008 SUV: OPTIONS PRICE LIST

ALL-NEW PEUGEOT 2008 SUV CHOOSE YOUR OPTIONS (1/2)

	CODE	 ACTIVE	 ALLURE	 GT LINE	 GT	RRSP
PAINT						
Bianca White (available on Petrol / Diesel versions only)	POWP	○	○	-	-	€235
Onyx Black	POXY	○	○	○	○	€370
Metallic paint	M0..	○	○	○	○	€565
Special / pearlescent paint (Vertigo Blue, Elixir Red, Pearl White)	M6../M5..	○	○	○	○	€760
Black Diamond Roof (Not available with Onyx Black paint)	JD04	-	○	●	●	€295
SAFETY AND SECURITY						
AEBS3 - Active Safety Brake (night function, cyclists, pedestrians)	ZVCA	○/● EV	○/● EV	-	-	€450
Drive Assist Pack: Adaptive Cruise Control 30 (manual versions) - GT Line	ZVCB	-	○	○	-	€741 Allure €295 Active
Drive Assist Pack Plus: Adaptive Cruise Control with Stop and Go (EAT8 versions) + Lane Positioning Assist - Allure	ZVCC	-	○	-	-	€935
Drive Assist Pack Plus: Adaptive Cruise Control with Stop and Go (EAT8 versions) + Lane Positioning Assist - GT Line	ZVCC	-	-	○	●	€490
COMFORT & CONVENIENCE						
Semi Auto Park Assist (manual gearbox)	WY45	-	-	○	-	€780
Full Park Assist (automatic gearbox)	WY42	-	-	○	●	€975 GT Line €685 GT
11 kW triphase On board charger (EV versions)	LZ04	○	○	○	○	€390
Peugeot 'Open and Go' handsfree access and start	YD07	-	○	○	○	€390
Electric, heated and power folding door mirrors (includes electric rear windows)	RL05	-/○EV	●	●	●	€190
Automatic air conditioning	RE07	○/● EV	●	●	●	€390

○ = Optional. ● = Standard. - = Not available.

NEW PEUGEOT 2008 SUV: OPTION PRICE LIST

ALL-NEW PEUGEOT 2008 SUV CHOOSE YOUR OPTIONS (2/2)

KEY: ○ = Optional. ● = Standard. - = Not available.



ACTIVE



ALLURE



GT LINE



GT

RRSP

CODE

INTERIOR FEATURES

Seating: Nappa full grain leather seat trim with 'Asphalt' double stitch detail, Driver seat multi-way electric adjustment (includes electric lumbar adjustment), Driver seat multi-point massage function (not available on EV)

O845

-

○

○

○

€2245 Allure
€2047 GT Line
€1365 GT

CONNECTED 3D NAVIGATION

10" capacitive colour touchscreen with 3D Navigation

ZJ17

-

●

●

●

€975

Smartphone charging plate

E301

○

○

○

○

€195

FOCAL® Premium HiFi speaker system (Petrol/Diesel versions) (brings in puncture repair kit in lieu of space saver spare wheel)

UN02

-

-

○

○

€1075

EXTERIOR FEATURES

Cielo panoramic glass roof

TC07

-

○

○

○

€1170



NEW PEUGEOT 2008 SUV: RANGE EQUIPMENT

ALL-NEW PEUGEOT 2008 SUV EQUIPMENT (1/3)



SAFETY & SECURITY

	ACTIVE	ALLURE	GT LINE	GT
ABS (Anti-lock Braking System) with EBD (Electronic Braking Distribution) and EBA (Emergency Braking Assistance)	●	●	●	●
Airbags: Adaptive driver and front passenger airbags (includes passenger airbag deactivation function)	●	●	●	●
Airbags: Front and rear curtain airbags	●	●	●	●
Automatic door locking when moving off	●	●	●	●
Automatic hazard light activation upon heavy brake application	●	●	●	●
Child locking functionality on rear doors	●	●	●	●
Deadlocking	●	●	●	●
Electronic code immobiliser	●	●	●	●
ESP (Electronic Stability Programme) with Hill Start Assist	●	●	●	●
Front optimised safety headrests and rear retractable headrests (x3), height-adjustable.	●	●	●	●
Front and rear three-point retractable seatbelts, with force limiters	●	●	●	●
Front and rear disc brakes	●	●	●	●
Gear Shift Indicator (manual version only)	●	●	●	-
Headlights left on audible warning	●	●	●	●
Isofix child seat fittings (x2) in the second row	●	●	●	●
Isofix child seat fittings – passenger seat	-	-	●	●
PEUGEOT Connect SOS and Assistance	●	●	●	●
Programmable cruise control and speed limiter	●	●	●	●
Drive Assist Pack: Adaptive cruise control (manual gearbox)	-	○	○	-
Drive Assist Pack Plus: Adaptive cruise control with Stop & Go function, Lane positioning assist (automatic gearbox)	-	○	○	●
Lane Keeping Assist	●	●	●	●
Speed limit recognition and recommendation	●	●	●	●
Active Safety Brake (pedestrians)	●	●	-	-
Active Safety Brake (Night function, cyclists, pedestrians)	○/● EV	○/● EV	●	●
Active blind spot monitoring	-	-	-	●
Driver attention warning	●	●	●	●
Seatbelt unfastened on the move audible and visual alert for front and rear seats	●	●	●	●
Space saver spare wheel (Petrol/Diesel versions)	●	●	●	●
Puncture kit (EV versions)	●	●	●	●
Tyre pressure sensors	●	●	●	●
Exterior temperature indicator with ice warning	●	●	●	●

COMFORT & CONVENIENCE

	ACTIVE	ALLURE	GT LINE	GT
Manual air conditioning	●	-	-	-
Automatic dual zone climate control *	○/● EV	●	●	●
Pre-heating functionality (EV versions)	●	●	●	●
Low centre console	●	-	-	-
High centre console	○/● EV	●	●	●
Central front armrest with storage compartment *	-/● EV	●	●	●
Electric and heated door mirrors	●	-	-	-
Electric, heated and power folding door mirrors	-/○ EV	●	●	●
Manual rear view mirror	●	-	-	-
Electrochrome rear view mirror	-	●	-	-
Frameless Electrochrome rear view mirror	-	-	●	●
Manual parking brake	●	-	-	-
Electric parking brake *	○/● EV	●	●	●
7.4 kW monophasic On board charger (EV versions)	●	●	●	●
Electric power steering with reach and rake adjustable steering column	●	●	●	●
Electric power steering with reach and rake adjustable steering column	●	●	●	●
Front windscreen wiper with 'Magic Wash' cleaning system	●	●	●	●
Multifunction trip computer	●	●	●	●
'One-touch' electric front windows with pinch protection	●	●	●	●
'One-touch' electric rear windows with pinch protection	●	●	●	●
Manual rear windows	●	-	-	-
'One-touch' electric rear windows with pinch protection	-	●	●	●
Parking sensors – rear	●	●	●	●
Parking sensors – front and rear	-	●	●	●
Visio Park 1: 180° Colour Reversing Camera	●	●	●	●
PEUGEOT i-Cockpit®: compact steering wheel	●	●	●	●
PEUGEOT i-Cockpit®: 7.0" capacitive colour touchscreen	●	●	●	●
PEUGEOT i-Cockpit®: 10" capacitive colour touchscreen	-	○	●	●
PEUGEOT i-Cockpit® with 3.5" instrument panel display	●	-	-	-
PEUGEOT 3D i-Cockpit®: Configurable 3D head-up instrument panel	-	●	●	●
Push button start	●	●	●	●
Tailgate with heated rear windscreen & wiper blade	●	●	●	●
Rear windscreen wiper triggered automatically in reverse gear	●	●	●	●
Dark tinted rear side and tailgate windows	-	●	●	●

NEW PEUGEOT 2008 SUV: RANGE EQUIPMENT

ALL-NEW PEUGEOT 2008 SUV EQUIPMENT (2/3)

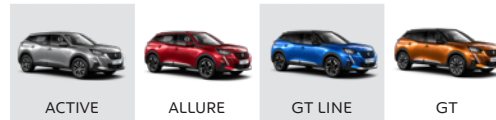

	ACTIVE	ALLURE	GT LINE	GT		ACTIVE	ALLURE	GT LINE	GT
INTERIOR FEATURES					IN-CAR ENTERTAINMENT				
Orange contrast stitching to front centre console, door panels and dashboard facia	●	-	-	-	Bluetooth® telephone facility	●	●	●	●
Light blue contrast stitching to front centre console, door panels and dashboard facia	-	●	-	-	DAB Radio (Digital Audio Broadcasting)	●	●	●	●
Lime green contrast stitching to armrest, front centre console, door panels and dashboard facia	-	-	●	●	Mirror Screen®: (Apple CarPlay™, Android Auto and MirrorLink®)	●	●	●	●
8-colour personalisable ambient lighting	-	-	●	●	Smartphone docking station	●	●	●	●
Dashboard, front door panel finish: Carbon effect	●	●	●	●	USB Socket (x1) front	●	-	-	-
Front and rear carpet mats in black with lime green stitch detail (Petrol / Diesel versions)	-	-	●	●	USB Socket (x2) front including 1 USB-C	○/● EV	●	●	●
Front and rear carpet mats in black with specific detailing (EV versions)	-	-	●	●	USB Socket (x2) rear	○/● EV	●	●	●
Gear lever – automatic in full grain leather and satin chrome	●	●	●	●	Voice recognition (radio, navigation and telephony features)	●	●	●	●
Gear lever – manual in satin chrome (6 speed gearbox)	●	●	●	-	6-Speaker radio, MP3 compatible	●	●	●	●
Front interior light with reading spotlights (x2)	●	●	-	-	12v socket	●	●	●	●
Front LED interior light with reading spotlights (x2) and rear LED interior light with timer	-	-	●	●	3D Navigation	○	○	●	●
Leather steering wheel	●	●	-	-	Smartphone Charging Plate	○	○	○	●
Mistral full-grain perforated leather steering wheel with Aikinite stitch detail and satin chrome 'GT' emblem	-	-	-	●	LIGHTING AND VISIBILITY				
Mistral full-grain perforated leather steering wheel with Aikinite stitch detail and satin chrome 'GT Line' emblem	-	-	●	-	Eco LED headlights	●	●	-	-
Pedals: aluminium	-	-	●	●	Full LED headlights with Smartbeam Assist	-	-	●	●
Stainless steel door sill scuff plates	-	-	●	●	Front fog lights	●	●	●	●
'Piano' keys: Gloss black plated toggle switches to access main functions of the vehicle	●	●	●	●	LED daytime running lights with distinctive 'Tooth' design	●	●	-	-
'Piano' keys: Gloss black plated toggle switches to access touchscreen functions**	-	●	●	●	LED daytime running lights: 3-Claw Headlight with distinctive 'Tooth' design	-	-	●	●
Roof lining – Light Grey	●	●	-	-	LED side indicator lights integrated into door mirrors	-	-	●	●
Roof lining – Mistral black	-	-	●	●	Rear numberplate lights (x2)	●	●	●	●
Seating: driver and front passenger seat manual adjustment (longitudinal and back rest angle)	●	●	●	●	Rear full LED 3D PEUGEOT signature 'Claw Effect' lights (with daylight function)	-	●	●	●
Seating: driver seat mechanical height adjustment	●	●	-	-	Rear reversing lights	●	●	●	●
Seating: driver and front passenger seat mechanical height adjustment	-	-	●	●	Visibility pack: automatic lights	●	●	●	●
Seating: – 1/3 – 2/3 folding rear seat	●	●	●	●	Visibility pack: automatic windscreen wipers *	-	●	●	●
Seating: driver and front passenger comfort seats	●	●	-	-	Visibility pack: 'follow me home' headlights	●	●	●	●
Seating: driver and front passenger sport seats	-	-	●	●					
Seating: Tri-material 'Pneuma' and 'Rimini' cloth seat trim with orange double stitch detail	●	-	-	-					
Seating: Tri-material 'Traxx' leather effect and 'Isabella' cloth seat trim with light blue double stitch detail	-	●	-	-					
Seating: Tri-material 'Capy' leather effect and 'Isabella' cloth seat trim with lime green double stitch detail	-	-	●	-					
Seating: Tri-material grey Alcantara® and 'Mistral' cloth seat trim with lime green stitch detail (Petrol/Diesel versions)	-	-	-	●					
Seating: Tri-material grey Alcantara® and 'Mistral' cloth seat trim with lime green and blue stitch detail (EV versions)	-	-	-	●					
Seating: Front heated seats (x2)	-	-	●	●					
Standard boot floor	●	-	-	-					
Modular boot floor	○	●	●	●					



NEW PEUGEOT 2008 SUV: RANGE EQUIPMENT

ALL-NEW PEUGEOT 2008 SUV EQUIPMENT (3/3)



ACTIVE

ALLURE

GT LINE

GT

EXTERIOR FEATURES

	ACTIVE	ALLURE	GT LINE	GT
Body-colour exterior door handles	•	•	•	•
Door mirror shells: Colour coded	•	•	-	-
Door mirror shells: Gloss Black	-	-	•	•
Gloss black B-pillar	-	•	•	•
Gloss black window surround	-	-	•	•
Wheel arch extensions	-/• EV	-/• EV	•	•
Gloss black rear cluster connecting strip	•	•	•	•
GT Line model designation badging on tailgate	-	-	•	-
GT model designation badging on tailgate	-	-	-	•
Dichroic badging including front lion, 'e' monogram on C-pillar and tailgate (EV versions)	•	•	•	•
Model designation badges front and rear	•	•	•	•
Radiator grille: Chrome chequered	•	•	-	-
Radiator grille: Dark chrome chequered and gloss black edge trim	-	-	•	•
Radiator grille: body-colour chequered and gloss edge trim (EV versions)	•	•	•	•
Radiator grille: Black higher part (Petrol/Diesel)	•	-	-	-
Radiator grille: Gloss black higher part (Petrol/Diesel)	-	•	•	•
Radiator grille: Colour coded higher part (EV versions)	•	•	•	•
Front bumper: Black lower part	•	-	-	-
Front bumper: Chrome lower part	-	•	•	•
Front wing trim: black (Petrol and Diesel versions)	•	-	-	-
Front wing trim: black with gloss black detail (Petrol and Diesel versions)	-	•	•	•
Front wing trim: black with gloss black detail and GT Line badging (Petrol and Diesel versions)	-	-	•	-
Front wing trim: black with gloss black detail and GT badging (Petrol and Diesel versions)	-	-	-	•
Front wing trim: black with gloss black detail and 'e' monogram (EV versions)	•	•	•	•
Exhaust pipe: chrome (Petrol/Diesel versions)	-	-	•	-
Exhaust pipe: twin chrome right hand side (Petrol/Diesel versions, PureTech 130 and 155 engines only)	-	•	•	•
Diamond Black roof	-	-	•	•
Colour coded rear spoiler	•	•	-	-
Diamond black rear spoiler	•	•	•	•
Gloss black roof bars	•	-	-	•
16" 'ELBORN' Alloys	•	-	-	-
17" 'SALAMANCA' Alloys	-	•	•	-
18" 'EVISSA' Alloys	-	-	-	•



NEW PEUGEOT 2008 SUV: PAINT OPTIONS

ALL-NEW PEUGEOT 2008 SUV

CHOOSE YOUR PAINT

○ = Optional. ● = Standard. - = Not available.

		ACTIVE 2008	ACTIVE e-2008	ALLURE 2008	ALLURE e-2008	GT LINE 2008	GT LINE e-2008	GT 2008	GT e-2008
SOLID PAINT									
Bianca White	WPPO	○	-	○	-	-	-	-	-
Onyx Black	XYPO	○	○	○	○	○	○	○	○
METALLIC PAINT									
Orange Fusion	ZTM0	●	●	●	●	●	●	●	●
Cumulus Grey	F4M0	○	○	○	○	○	○	○	○
Nimbus Grey	VLM0	○	-	○	-	○	-	○	-
SPECIAL PAINT									
Elixir Red	VHM5	○	○	○	○	○	○	○	○
Vertigo Blue	SMM6	○	-	○	-	○	-	○	-
Pearlescent White	N9M6	○	○	○	○	○	○	○	○



ORANGE FUSION



CUMULUS GREY



ONYX BLACK



VERTIGO BLUE



BIANCA WHITE



NIMBUS GREY



ELIXIR RED



PEARLESCENT WHITE

NEW PEUGEOT 2008 SUV: UPHOLSTERY OPTIONS

ALL-NEW PEUGEOT 2008 SUV

CHOOSE YOUR UPHOLSTERY OPTIONS

	ACTIVE 2008 SUV / e-2008 SUV	ALLURE 2008 SUV / e-2008 SUV	ALLURE 2008 SUV	GT LINE 2008 SUV / e-2008 SUV	GT LINE 2008 SUV	GT 2008 SUV	GT e - 2008 SUV	GT 2008 SUV
UPHOLSTERY OPTIONS								
Upholstery	Tri-material 'Pneuma' and 'Rimini' cloth seat trim	Tri-material 'Traxx' leather effect and 'Isabella' cloth seat trim	Nappa Mistral full grain leather seat trim	Tri-material 'Capu' leather effect and 'Isabella' cloth seat trim	Nappa Mistral full grain leather seat trim	Tri-material mistral Alcantara® and cloth seat trim	Tri-material grey Alcantara® and cloth seat trim	Nappa Mistral full grain leather seat trim
Trim Code	MZ0Z	OPA8	OP4H	OPA7	OP4H	OPD7	OP2A	OP4H
Top-Stitching	Orange	Light Blue	Charcoal Grey	Lime Green	Charcoal Grey	Lime Green	Lime Green and Light Blue	Charcoal Grey
Availability	●	●	○	●	○	●	●	○



Active

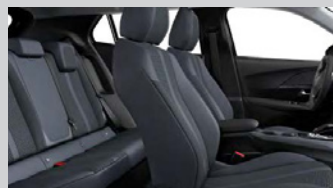

Allure



GT Line



GT



GT EV



Nappa Leather

ALL-NEW PEUGEOT e-2008

WHEEL

	ACTIVE 2008	ACTIVE e-2008	ALLURE 2008	ALLURE e-2008	GT LINE 2008	GT LINE e-2008	GT 2008	GT e-2008
WHEEL DESCRIPTION								
16" 'ELBORN' alloy wheels	●	●	-	-	-	-	-	-
17" 'SALAMANCA' diamond cut alloy wheels	-	-	●	●	●	●	-	-
18" 'BUND' diamond cut alloy wheels	-	-	○	-	○	-	●	●
18" 'EVISSA' alloy wheels	-	-	-	-	○	-	○	-

○ = Optional. ● = Standard. - = Not available.



16" 'ELBORN' alloy wheels



17" 'SALAMANCA' diamond cut alloy wheels



18" 'BUND' diamond cut alloy wheels



18" 'EVISSA' alloy wheels

NEW PEUGEOT 2008 SUV: TECHNICAL SPECIFICATIONS

ALL-NEW PEUGEOT 2008 SUV

TECHNICAL SPECIFICATION - PETROL/DIESEL

	PETROL				DIESEL
	1.2L PureTech 100 S&S 6-speed manual	1.2L PureTech 130 S&S 6-speed manual	1.2L PureTech 130 EAT8 S&S 8-speed automatic	1.2L PureTech 155 EAT8 S&S 8-speed automatic	1.5L BlueHDi 100 6-speed manual
POWERTRAIN					
Fuel type	Petrol	Petrol	Petrol	Petrol	Diesel
Stop and Start functionality	●	●	●	●	●
Cubic capacity (cc)	1199	1199	1199	1199	1499
Maximum power bhp (Kw)	101 (55) @ 5550	131 (96) @ 5500	131 (96) @ 5500	155 (114) @ 5500	102 (75) @ 3500
Maximum torque lb/ft (Nm)	151 (205) @ 1750	170 (230) @ 1750	170 (230) @ 1750	177 (240) @ 1750	184 (250) @ 1750
6-speed manual	●	●	-	-	●
8-speed automatic	-	-	●	●	-
BRAKES					
Front and rear discs	●	●	●	●	●
SUSPENSIONS AND TYRES					
Front suspension	Pseudo MacPherson	Pseudo MacPherson	Pseudo MacPherson	Pseudo MacPherson	Pseudo MacPherson
Rear suspension	De-formable Crossmember	De-formable Crossmember	De-formable Crossmember	De-formable Crossmember	De-formable Crossmember
Size - 16" tyres	215/65 R16 H	215/65 R16 H	215/65 R16 H	215/65 R16 H	215/65 R16 H
Size - 17" tyres	215/60 R17 H	215/60 R17 H	215/60 R17 H	215/60 R17 H	215/60 R17 H
Size - 18" tyres	215/55 R18 H	215/55 R18 H	215/55 R18 H	215/55 R18 H	215/55 R18 H
PERFORMANCE					
Maximum speed (kph)	185	196	196	208	185
Acceleration 0-100 kph driver only (sec)	14.9	9.9	10.8	8.7	10.2
FUEL CONSUMPTION INFORMATION (WLTP V. Low / V. High Fuel Consumption)					
Fuel Consumption: Combined (litres/100km)	5.4 - 6.1	5.6 - 6.5	6.0 - 6.7	6.1 - 6.8	4.5 - 5.2
Carbon Dioxide (CO2) emissions Combined (g/km)	105 - 113	103 - 109	109 - 117	113 - 121	96 - 102
VEHICLE WEIGHT INFORMATION (KG)					
Gross vehicle weight	1710	1715	1740	1748	1731
Mass in service	1263	1267	1280	1280	1280
Kerb weight	1338	1342	1355	1355	1355
Gross train weight	2910	2915	2940	2948	2931
Maximum braked trailer weight	1200	1200	1200	1200	1200
Maximum tow ball weight	48	48	48	48	48



NEW PEUGEOT 2008 SUV: TECHNICAL SPECIFICATIONS

ALL-NEW PEUGEOT e-2008 SUV TECHNICAL SPECIFICATION - ELECTRIC

ELECTRIC	
	Electric 50 kWh 136
ELECTRIC MOTOR	
Maximum power hp (kW)	136 (100)
Maximum torque lb/ft (Nm)	221 (300) @ 3674
Battery Capacity (kWh) / Battery power (kW)	56 / 100
Electric Range WLTP (km)	310
On Board Charger (kW)	7.4
TRANSMISSION	
Type	Automatic
Number of gears	One
BRAKES	
Front and rear discs	●
SUSPENSIONS AND TYRES	
Front suspension	Pseudo MacPherson
Rear suspension	Panhard bar rear train
Size - 16" tyres	215/60 R16 P
Size - 17" tyres	215/60 R17 P
Size - 18" tyres	215/55 R18 P
REGULATED EMISSIONS	
Carbon monoxide (mg/km)	-
Total hydrocarbons (mg/km)	-
Carbon Dioxide (CO2) emissions Combined (g/km)**	0
Nitrogen Oxides (mg/km)	-
Total Hydrocarbons + Nitrogen Oxides (mg/km)	-
Particulate Matter (mg/km)	-
PERFORMANCE	
Maximum speed (mph)	149
Acceleration 0-100 kph driver only (sec)	TBC
VEHICLE WEIGHT INFORMATION (KG)	
Gross vehicle weight	2030
Mass in service	1662
Kerb weight	1548
Gross train weight	-
Maximum braked trailer weight	-
Maximum tow ball weight	-



NEW PEUGEOT 2008 SUV: DIMENSIONS

ALL-NEW PEUGEOT e-2008 SUV DIMENSIONS

LENGTH

EXTERNAL DIMENSIONS

Length (mm)	4300
Width (mm)	1770
Height without / with roof bars (mm)	1530/1550
Wheelbase (mm)	2605
Front / rear overhang (mm)	870 / 825
Front / rear track width (mm)	1540
Turning circle between pavements (m)	10.4

INTERNAL DIMENSIONS

Number of seats	5
Front / rear elbow room (mm)	TBC
Front / rear shoulder room (mm)	TBC
Front / rear head room (mm)	TBC

BOOT, STORAGE & FUEL TANK

Length with rear seat back up / folded (mm)	791
Maximum loading length (mm)	TBC
Width between wheel housings (mm)	1014
Height under parcel shelf / head room (mm)	488
Opening of boot, height / width (mm)	979
Min. boot volume (dm ³ VDA 210)	434
Max. boot volume (dm ³ VDA 214)	1467
Total volume of storage areas in the passenger compartment (litres)	32
Fuel tank capacity (litres)	44 in Puretech / 41 in BlueHdi

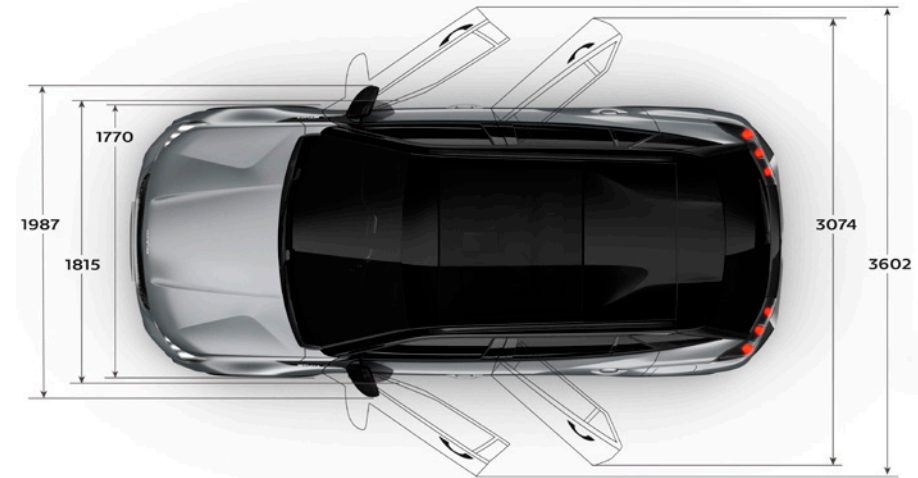
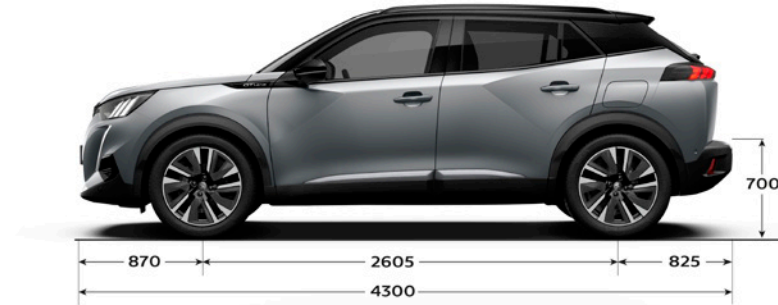

WIDTH/HEIGHT

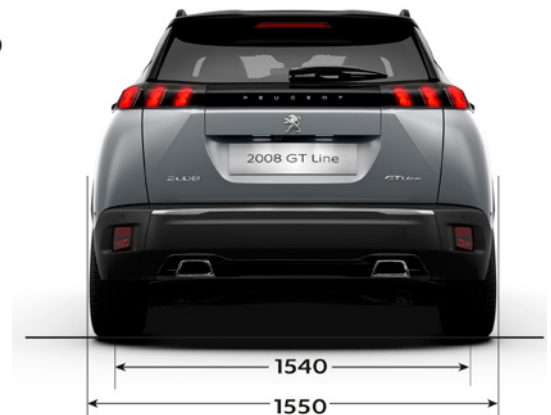

NEW PEUGEOT 2008 SUV: DIMENSIONS

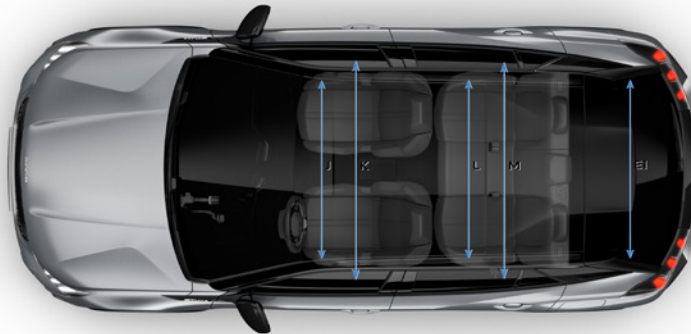
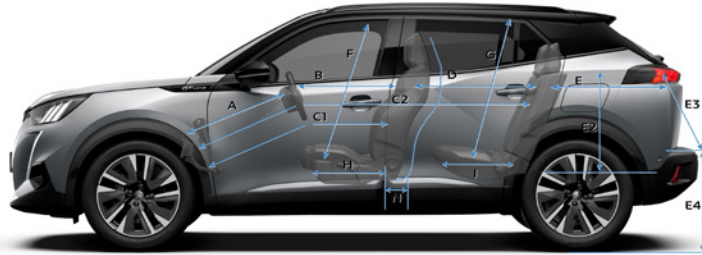

A	704
B	649
C1	884
C2	1756
D	872
E	791
E1	1014
E2	545
E3	819
E4	700/709
F	906
G	889
H	385,2
I	446
J	1408
K	1370
L	1378
M	1317
N	238,5

BOOT



434 L



E&OE FEBRUARY 2020. FOR FURTHER INFORMATION TALK TO YOUR LOCAL PEUGEOT DEALER OR SEE WWW.PEUGEOT.IE.

The information contained in this specification sheet, is based on the data and images available at the time of publication. Some photography may feature left hand drive models. All images shown are for illustration purposes only. Photographic processes used may alter the depth and tone of the colours shown. As part of a policy on continuous specification improvement, Peugeot reserves the right to modify colours, trims, engine range, options and standard equipment at any time. This specification sheet is not a contractual document or offer of sale.

The specified fuel consumption and emission values are the official figures obtained from tests under standardised EU test conditions in accordance with the Worldwide Harmonized Light Vehicles Test Procedure (WLTP), a more realistic test method for measuring fuel consumption (l/100km) and CO2 emissions and are correct at the time of print. WLTP replaces the previous NEDC test method. The included values reflect the standard vehicle excluding additional equipment such as optional extras and accessories which may have an effect on the fuel consumption (l/100km) and CO2 emissions produced. You can discover more about the WLTP at peugeot.ie/brand-and-technology/wltp