



PEUGEOT EXPERT COMBI
PRICES, EQUIPMENT & TECHNICAL SPECIFICATIONS

November 2019: E & OE



PEUGEOT

PEUGEOT EXPERT COMBI: PRACTICALITY FOR LIFE

INTRODUCING THE NEW PEUGEOT EXPERT COMBI

The new Peugeot Expert Combi is available in three lengths* - Compact, Standard or Long. It can carry up to 9 passengers, thanks to its flexible seating arrangement, even in its shortest Compact form. Ideal for families, groups or sports clubs who are looking for a maximum number of seats and space, the new Peugeot Expert Combi offers you a practical solution for whatever life throws your way.

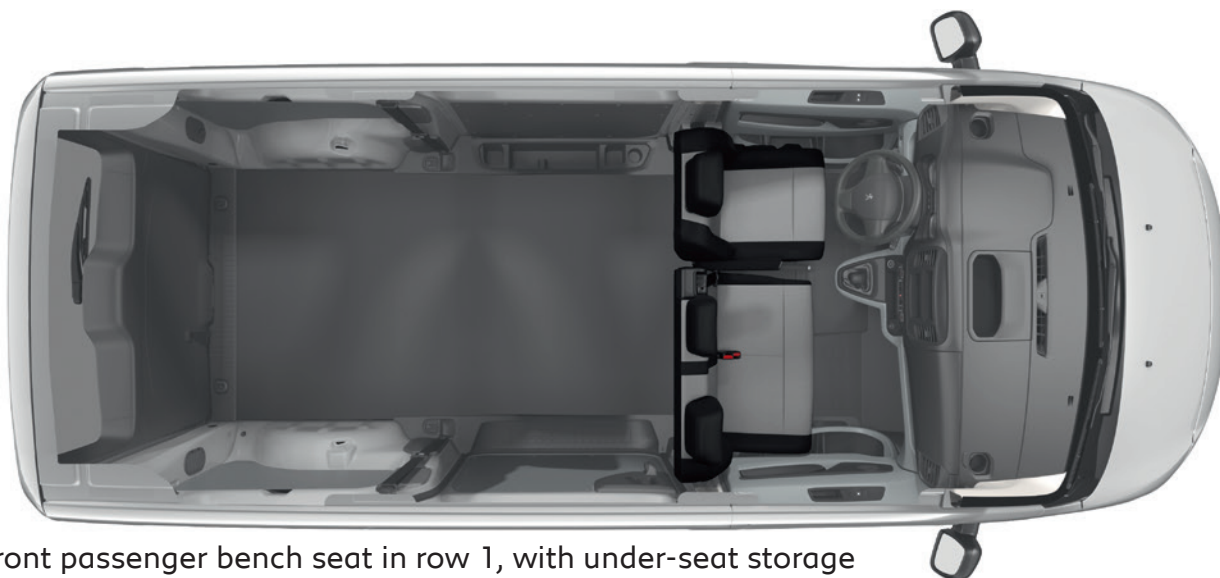

Dual front passenger bench seat in row 1, with under-seat storage

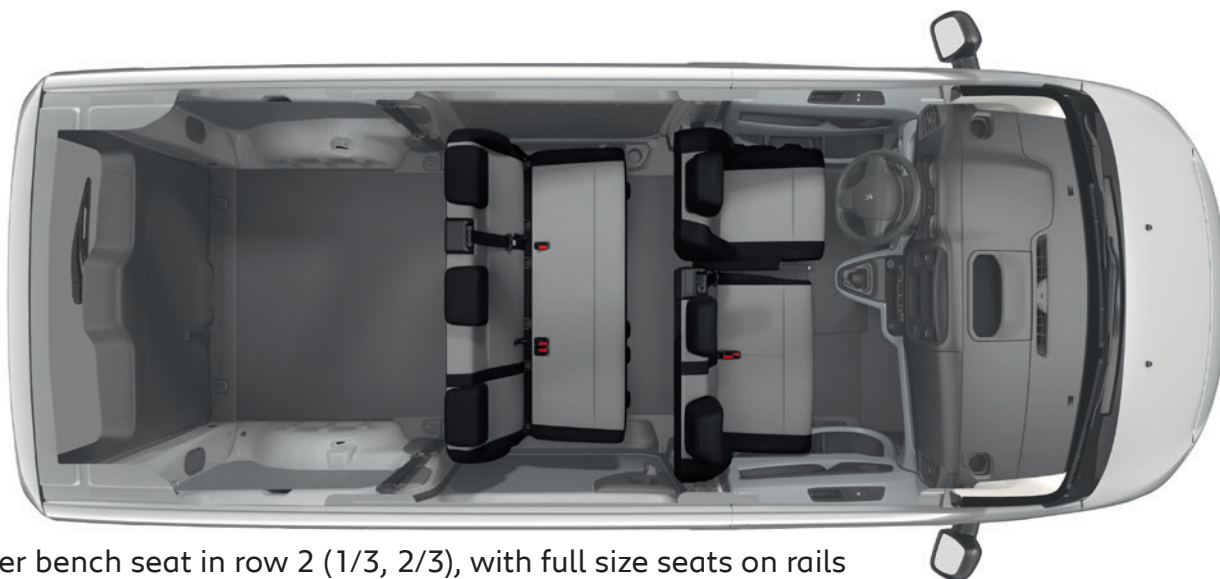

3-seater bench seat in row 2 (1/3, 2/3), with full size seats on rails



3-seater bench seat in row 3 with full size seats on rails

NEW EXPERT COMBI ACTIVE

Exterior Style

- Black bumpers, door mirrors, door handles and side rubbing strips
- Headlights with integrated Daytime Running Lights (DRLs)
- 16" steel wheels

Safety & Security

- ABS with Electronic Brake Force Distribution (EBFD)
- Electronic Stability Control (ESC)
- Hill Start Assist function
- Driver and front passenger airbags (passenger airbag with deactivation switch)
- Front lateral airbags
- Nine 3-point inertia reel seat belts
- Tyre Pressure Sensor
- Remote central locking with deadlocks
- Cruise control with speed limiter
- Full size spare wheel
- Unfastened seatbelt visual warning system on driver and front passenger seats (with dual bench or single passenger seat)

Comfort & Convenience

- Height and reach adjustable steering wheel
- Power assisted steering
- Front electric windows one touch operation
- 2 cup holders, one on driver side and one on passenger side on the top of the dashboard
- Directional heating and air recycling via 4 dashboard air vents
- Air conditioning
- Glovebox (Illuminated)
- Storage area on the top of the dashboard
- Driver and passenger sunvisor with ticket holder
- Courtesy light to cabin
- Rubber flooring in cabin

Technology & Entertainment

- DAB radio with Bluetooth, USB socket and audio jack
- 12 volt sockets (cabin X2)

Seating

- Driver's seat rake and reach adjustable
- Front seat height-adjustable head restraints
- Height adjustable driver's seat with lumbar adjustment and armrest
- Dual front passenger bench seat with under-seat storage
- 3-seater bench (1/3, 2/3) on row 2 with full size rear seats on rails
- 3-seater bench on row 3 with full size rear seats on rails
- 3 Isofix points on row 2

Lighting and Visibility

- Electrically adjustable and heated door mirrors
- High level third brake light

Doors and Windows

- Twin sliding doors (not electric)
- Laminated windscreen
- Fixed side windows with noise-reducing tinted glass (to approx. 30% opacity)
- Tailgate with heated window and wash-wipe

PEUGEOT EXPERT COMBI: EU6.2 PRICE LIST

Length	Model Description	RRSP*	WLTP CO2	VRT Band	Annual Road Tax	Engine CC	Fuel Type	Transmission
Compact	1.5 BlueHDi 100bhp 9-Seats	€31,460	170	B1	€270	1499	Diesel	6-speed
	1.5 BlueHDi 120bhp 9-Seats	€32,150	167	B1	€270	1499	Diesel	6-speed
	2.0 BlueHDi 150bhp 9-Seats	€36,590	184	C	€390	1997	Diesel	6-speed
Standard	1.5 BlueHDi 100bhp 9-Seats	€32,790	170	B1	€270	1499	Diesel	6-speed
	1.5 BlueHDi 120bhp 9-Seats	€33,470	168	B1	€270	1499	Diesel	6-speed
	2.0 BlueHDi 150bhp 9-Seats	€37,920	188	C	€390	1997	Diesel	6-speed
Long	1.5 BlueHDi 120bhp 9-Seats	€34,800	170	B1	€270	1499	Diesel	6-speed
	2.0 BlueHDi 150bhp 9-Seats	€39,250	190	C	€390	1997	Diesel	6-speed

*Dealer delivery related charges & metallic paint not included.



PEUGEOT EXPERT COMBI: OPTIONS PRICE LIST

	CODE	COMBI	RRSP
PAINT			
Metallic	..M0	○	€735
Bianca White	..0N	●	€0
Special Paint		○	€1095
SAFETY AND SECURITY			
Alarm	AB08	○	€390
Curtain airbags	NF04	○	€155
Look pack - colour coded bumpers, mirrors and door handles (half painted rear bumper on long)	PD22/PD69	○	€820
Rear parking sensors	UB01	○	€410
Front and rear parking sensors with blind spot monitoring	UB03	○	€1,540
Rear parking sensors with reverse camera displayed on rear view mirror	UB09	○	€605
INTERIOR FEATURES			
Handsfree sliding doors	D501	○	€955
Electric folding and heated mirrors	HU02	○	€235
Automatic dualzone airconditioning	RE07	○	€1,640
Monobloc and folding bench on row 3	AN15	○	€390
EXTERIOR FEATURES			
Xenon headlights	LA04	○	€955
Foglights	PR01	○	€195
Dark privacy glass rows 2 and 3	VD18	○	€140
IN CAR ENTERTAINMENT			
7" Touchscreen (incl Bluetooth, USB, 12V socket, Mirrorscreen: Android Auto and Apple Carplay)	WL3L	○	€470
3D Navigation and voice recognition(radio, navigation and telephony features)	WL3J	○	€1,055

PEUGEOT EXPERT COMBI: RANGE EQUIPMENT

	COMBI ACTIVE
COMFORT & CONVENIENCE	
Height and reach adjustable steering wheel	●
Power assisted steering	●
Front electric windows with 'one-touch' operation	●
Directional heating and air recycling via 4 dashboard air vents	●
Air conditioning	●
2 cup holders, one on driver side and one on passenger side on the top of the dashboard	●
SAFETY & SECURITY	
ABS with Electronic Brake Force Distribution (EBFD)	●
Electronic Stability Control (ESC)	●
Hill Start Assist function	●
Tyre pressure sensors	●
Driver and front passenger airbags. Passenger airbag deactivation switch	●
Front lateral airbags	●
Nine 3-point inertia reel seat belts	●
Unfastened seatbelt visual warning system on driver and front passenger seats (with dual bench or optional single passenger seat)	●
Remote central locking with deadlocks	●
Cruise control with programmable speed limiter	●
Central locking push button on dash	●
Automatic door locking (activated by vehicle travelling over 6kph)	●
Rolling code transponder immobiliser	●
Visible VIN at base of windscreen	●
Locking fuel filler cap	●
Automatic fuel cut-off & door unlocking in event of accident	●
Height-adjustable 3-point pre-tensioner seat belts with force limiter (central seatbelt on dual passenger seat not height-adjustable & no pre-tensioner)	●
Height-adjustable front head restraints	●
TECHNOLOGY & ENTERTAINMENT	
DAB radio with Bluetooth, USB port and audio jack	●
12 volt sockets (cabin x 2)	●
INSTRUMENTS	
Speedometer with digital odometer, digital trip recorder & rev counter	●
Water temperature and fuel gauges, oil level indicator	●
Distance to next service indicator	●
LCD central display & trip computer	●
Clock	●
Lights on warning	●
Side, headlamp and indicator warning	●
Battery charge warning	●
Door open warning	●

PEUGEOT EXPERT COMBI: RANGE EQUIPMENT

	COMBI ACTIVE
EXTERIOR STYLE	
Black front and rear bumpers	●
Black side rubbing strips	●
Black exterior door handles	●
Black door mirrors	●
WHEELS & TYRES	
Full size steel spare wheel	●
16 inch steel wheels with black centre cap (215/65 R16 C): not available on BlueHDi 180 EAT6 automatic version	●
17 inch steel wheels with black centre cap (225/55 R17 C): Standard on BlueHDi 180 EAT6 automatic version only	●
DOORS & WINDOWS	
Twin sliding doors (not electric)	●
Laminated windscreen	●
Fixed side windows with noise-reducing tinted glass (to approx. 30% opacity)	●
Tailgate with heated window and wash-wipe	●
LIGHTING & VISIBILITY	
Halogen headlights with integrated daytime running lights (DRLs)	●
Remote headlamp adjustment from fascia	●
Reversing light	●
Rear fog light	●
High level third brake light	●
Heated and electrically adjustable door mirrors	●
TOWING	
Preparation for towbar: wiring and connector for towbar interface	●
INTERIOR SYTLE	
Grey "Silca" cloth trim	●
Driver and passenger sunvisor with ticket holder	●
Courtesy light to cabin	●
Rubber flooring in cabin	●
SEATING	
Driver's seat rake and reach adjustable	●
Front seat height-adjustable head restraints	●
Dual front passenger bench seat with under-seat storage.	●
Driver's seat with lumbar adjustment and armrest	●
3-seater bench in rows 2 and 3 with full size rear seats on rails	●
Isofix mounting points on row 2	●
STORAGE	
Glovebox (Illuminated)	●
Front door pockets	●
Open glove box on top of the dashboard	●

PEUGEOT EXPERT COMBI: CHOOSE YOUR PAINT COLOUR & UPHOLSTERY

		ACTIVE
Upholstery		Grey 'Silca' Cloth
Trim Code		42FR
Solid Paint		
Bianca White	WPP0	●
Metallic Paint		
Rich Oak	G6M0	○
Nimbus Grey	VLM0	○
Amber Red	V7M0	○
Pearl Sand	EUM0	○
Special Paint		
Dragon Blue	4PP0	○
Nera Black Pearl	9VM0	○
Cumulus Grey	F4M0	○

● Standard ○ Cost Option

SOLID PAINT



Bianca White

METALLIC COLOURS

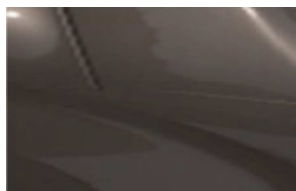

Rich Oak



Nimbus Grey

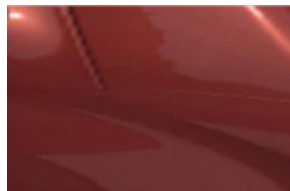

Amber Red



Pearl Sand

SPECIAL COLOURS



Dragoon Blue

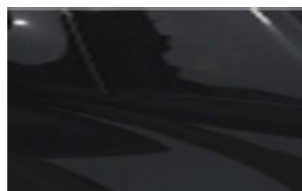

Nera Pearl Black



Cumulus Grey

WHEELS



16" steel wheel with black centre cap



17" steel wheel with black centre cap

PEUGEOT EXPERT COMBI: KNOW YOUR VEHICLE IN DETAIL

6.2 Technical Specifications: Engines, Performance & Weights

VERSIONS	1.5 BlueHDI 100bhp		1.5 BlueHDI 120bhp S&S			2.0 BlueHDI 150bhp S&S		
Length	Compact	Standard	Compact	Standard	Long	Compact	Standard	Long
ENGINE								
Capacity (cc)	1499		1499			1997		
Cylinders / Valves	4/8		4/8			4/16		
Max power (bhp/kW&rpm)	100/75@3500		120/88@3500			150/110 @ 4000		
Max torque (Nm/rpm)	199/270@1600		221/300@1750			273/370@2000		
Bore and stroke (mm)	75 x 84.8		75 x 84.8			85 x 88		
Fuel system	Diesel - High Pressure Turbo Charged Injection							
Euro status	EURO 6.2							
Stop & Start system	●		●			●		
TRANSMISSION								
Gearbox	Manual		Manual			Manual		
Number of gears	6		6			6		
PERFORMANCE (All figures driver alone)								
Max speed (kph)	157		172			184		
0-100kph (secs)	13.5		12			10.3		
ECONOMY Litres/100km								
Regulated emissions standard	Euro 6.2		Euro 6.2			Euro 6.2		
WLTP Combined drive cycle litres / 100km	6.5		6.4 - 6.5			7.0 - 7.2		
WLTP Carbon Dioxide (CO2) emissions (g/km)	170		167 - 170			184 - 190		
WEIGHTS (kg) with 9 seats								
Payload (1)	1039	1085	1037	1095	1125	1080	1070	1075
Kerb weight (2)	1646	1660	1648	1660	1660	1660	1740	1770
Gross Vehicle Weight (GVW)	2685	2745	2685	2755	2785	2740	2810	2845
Max plated front axle (3)	TBC	TBC	TBC	TBC	TBC	TBC	TBC	TBC
Max plated rear axle (3)	TBC	TBC	TBC	TBC	TBC	TBC	TBC	TBC
Gross Train Weight (GTW)	4070	4140	4085	4155	4190	4640	4710	4745
Maximum braked towing weight (4)	1800	1800	1800	1800	1800	2300	2300	2300
Maximum unbraked towing weight	TBC	TBC	TBC	TBC	TBC	TBC	TBC	TBC
Maximum towball weight	TBC	TBC	TBC	TBC	TBC	TBC	TBC	TBC
BRAKES Front/Rear								
Ventilated discs / discs								
Turning Circle between kerbs	11.3 for Compact/12.4 for Standard and Long							
SUSPENSION								
Fuel tank capacity Litres	70							

(1) Difference between GVW and kerb weight. (2) Without driver: kerb weight is calculated including oil, water, lubricants, tools, spare wheel and 90% full fuel tank. Weights may change with the addition of equipment. (3) Within limits of GVW. (4) Maximum recommended towing weight within limits of GTW.

PEUGEOT EXPERT COMBI: KNOW YOUR VEHICLE IN DETAIL

Dimensions & Volumes

VERSIONS	EXPERT COMBI		
	COMPACT	STANDARD	LONG
EXTERIOR DIMENSIONS (mm)			
Length	4609	4959	5309
Front overhang	881		
Wheelbase	2925	3275	
Rear overhang	803		1153
Width (excluding door mirrors)	1920		
Width (door mirrors unfolded)	2204		
Front track at wheel centre	1627		
Rear track at wheel centre	1600		
Height (1)	1905	1895	
DIMENSIONS OF REAR DOORS (mm)*			
Maximum width of rear doors	1229	1212	
Maximum height of rear doors	1181		
Minimum load sill height (1)	587	544	600
Maximum load sill height (1)	610	613	633
DIMENSIONS OF SIDE DOORS (mm)			
Maximum width of side doors	743	933	
Maximum height of side doors	1181		
INTERIOR DIMENSIONS (mm)			
Maximum load height	1334	1337	1339
Maximum load length (behind front seats)	2063	2413	2763
Load width between wheel arches	1228		
Maximum waist width 1st row / 2nd row / 3rd row	1515 / 1586 / 1570		
TURNING CIRCLE (m)			
Turning circle between kerbs	11.3	12.4	

(1) Vehicle in running order

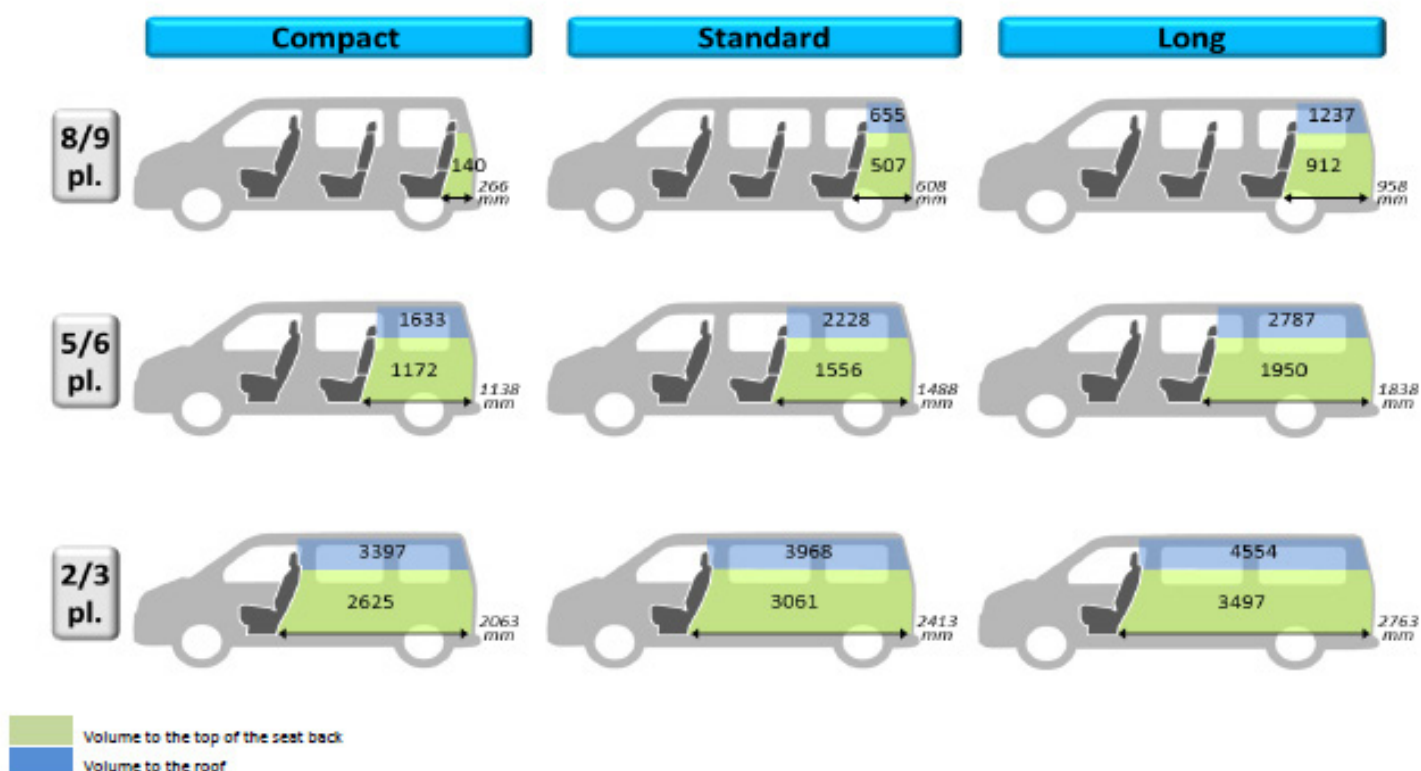

PEUGEOT EXPERT COMBI: KNOW YOUR VEHICLE IN DETAIL

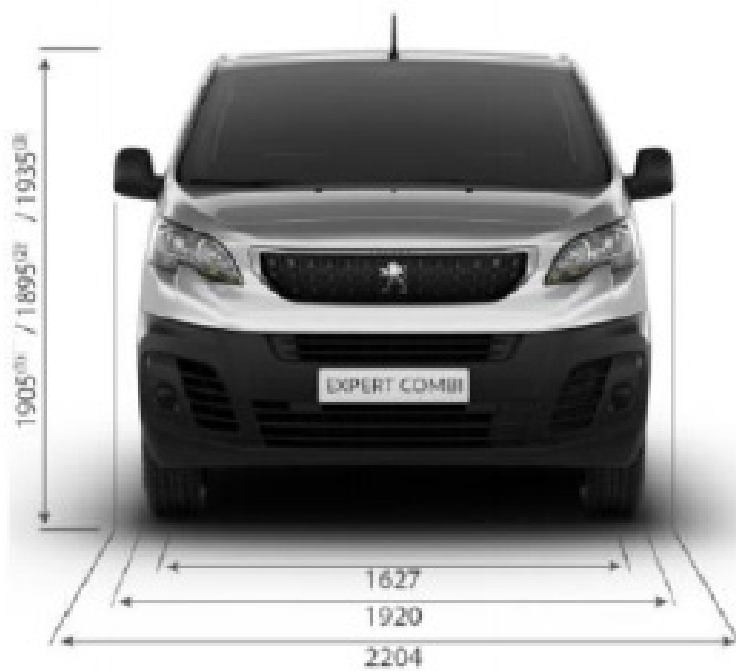

(1) Compact
(2) Standard
(3) Long



E&OE NOVEMBER 2019. FOR FURTHER INFORMATION TALK TO YOUR LOCAL PEUGEOT DEALER OR SEE WWW.PEUGEOT.IE.

The information contained in this specification sheet, is based on the data and images available at the time of publication. Some photography may feature left hand drive models. All images shown are for illustration purposes only. Photographic processes used may alter the depth and tone of the colours shown. As part of a policy on continuous specification improvement, Peugeot reserves the right to modify colours, trims, engine range, options and standard equipment at any time. This specification sheet is not a contractual document or offer of sale. The specified fuel consumption and emission values are the official figures obtained from tests under standardised EU test conditions in accordance with the Worldwide Harmonized Light Vehicles Test Procedure (WLTP), a more realistic test method for measuring fuel consumption (l/100km) and CO2 emissions and are correct at the time of print. WLTP replaces the previous NEDC test method. The included values reflect the standard vehicle excluding additional equipment such as optional extras and accessories which may have an effect on the fuel consumption (l/100km) and CO2 emissions produced. You can discover more about the WLTP at peugeot.ie/brand-and-technology/wltp